



LG HVAC SOLUTION

***MULTI V*™ 5**

2017



INDEX

WHY LG MULTI V 5

- 06 / COMPANY INTRODUCTION
- 08 / ENGINEERING CAPABILITY
- 10 / LG CONTROL SOLUTION
- 12 / MULTI V BRAND HISTORY
- 14 / 5 KEY FACTS ABOUT MULTI V 5
- 22 / BENEFITS FOR CUSTOMERS
- 26 / INCREASED EFFICIENCY CERTIFIED
BY EUROPEAN REGULATION

5 MAIN FEATURES

- 28 / ULTIMATE EFFICIENCY
- 36 / ULTIMATE PERFORMANCE
- 42 / ULTIMATE COMFORT
- 45 / ULTIMATE FLEXIBILITY
- 48 / ULTIMATE CONTROL

- 53 // HEAT RECOVERY
-

WHY

LG MULTI V 5

06 / COMPANY INTRODUCTION

- LG AIR SOLUTION AS A TOTAL HVAC & ENERGY SOLUTION PROVIDER
- INFRASTRUCTURE AT EUROPE

08 / ENGINEERING CAPABILITY

- HVAC TOOL & SUPPORT

10 / LG CONTROL SOLUTION

12 / MULTI V BRAND HISTORY

14 / 5 KEY FACTS ABOUT MULTI V 5

- DUAL SENSING CONTROL
- ULTIMATE INVERTER COMPRESSOR
- LARGE CAPACITY ODU WITH BIOMIMETICS TECHNOLOGY FAN
- OCEAN BLACK FIN HEAT EXCHANGER
- CONTINUOUS HEATING

22 / BENEFITS FOR CUSTOMERS

- CONSULTANTS & HVAC DESIGNERS
- INSTALLERS
- BUILDING OWNERS
- END USERS

26 / INCREASED EFFICIENCY CERTIFIED BY EUROPEAN REGULATION

LG AIR SOLUTION AS A TOTAL HVAC & ENERGY SOLUTION PROVIDER

INFRASTRUCTURE IN EUROPE



* LG Air Solution production sites

The LG Electronics Air Solution Business Unit is a provider of total HVAC and energy solution. The company offers a broad portfolio of air conditioner products that are compatible with any building anywhere, including compact residences, towering skyscrapers, massive factories and giant concert halls. As a true total HVAC and energy solution provider, LG also supplies even the largest buildings and industrial facilities with central air conditioning systems such as chillers and efficient control solutions.

The history of the business unit goes back to 1968, when LG (then called GoldStar) rolled out Korea's first residential air conditioner. As the company first began making chillers for large commercial buildings in 1970, the commercial air conditioning business has grown exponentially, especially

within the last 20 years. In 2008, LG sold its 100 millionth air conditioning unit, becoming the first company in the industry to reach that significant milestone. The success of LG air conditioners has allowed the company to become one of the major players in the highly competitive HVAC industry. By enhancing the industry's B2B infrastructure and finding further solutions for the HVAC sector, LG has risen to become a total HVAC solutions specialist. The company has steadily increased its sales and market share by introducing energy efficient and reliable HVAC solutions and actively pursuing new opportunities wherever they arise. This sustained, excellent performance is built on a solid foundation of global R&D and advanced manufacturing capabilities.



LG Air Conditioning Academy

LG has set up 19 official air conditioning academies in Europe, teaching much needed skills to thousands of current industry professionals including installers, consultants, designers, sales staff and service technicians. The academy program is being used to share expertise and cultivate these HVAC experts by providing a cutting-edge technical educational experience with the newest and most advanced technology and equipment. Moreover, as LG's entire product range is installed on site, professionals can be trained in a realistic way that offers them the chance to experience the latest products first-hand.





LG Energy Lab in Europe

Committed to meet all requirements regarding energy efficiency and environmental demands, LG has been running Energy Lab. LG Energy Lab is an innovative site dedicated to commercial and residential products in heating, ventilation and the latest energy efficient air conditioning solutions. Also as a showcase, LG Energy Lab is equipped with complete monitoring and control systems. The performance of all products will be tracked and analyzed by a team of Research and Development engineers based in France and Korea, ensuring efficiency and reliability during the whole product lifecycle.



European Air Conditioning Distribution Center

LG's European Air Conditioning Distribution Center is located in Oosterhout, the Netherlands. Supplying and delivering products all over Europe, this distribution hub has contributed to smooth and rapid delivery, direct shipping for smaller orders and delivery tailored to air conditioners. The hub tries to manage inventory efficiency by taking advantage of LG EU's established inventory pool.

-  LG Air Conditioning Academy
-  European Distribution Center
-  Europe Energy Lab



ENGINEERING CAPABILITY : HVAC TOOL & SUPPORT

From planning to service & maintenance and then to de-construction, an architectural project goes along many stages from the beginning to the end of its lifecycle. Along those stages, various engineering tools are applied to solve the diverse issues happening in each stage, with the most optimal solution possible. Due to the usage of such tools, buildings are effectively designed, built, supervised, and maintained throughout the lifecycle.

Dedicated to provide the best HVAC engineering support, LG Electronics Air-Solution Business Unit offers several engineering tools and solutions focused on HVAC, during the overall lifecycle of a building, related to the three categories: I. Draft Energy Estimation & Energy Modeling, II. Model Selection & Design, and III. Installation Environment Simulation. Among them, the LATS* Program series has been developed to offer the best and the most optimized tool for LG HVAC systems, providing our customers a faster, easier, and a more accurate way in everyday duties of Model-selection, Draft Energy Estimation & Designing, and many more.

* LATS : LG Air-conditioner Technical Solution



I
Energy Estimation & Energy Modeling



II
Model Selection & Design



III
Installation Environment Simulation

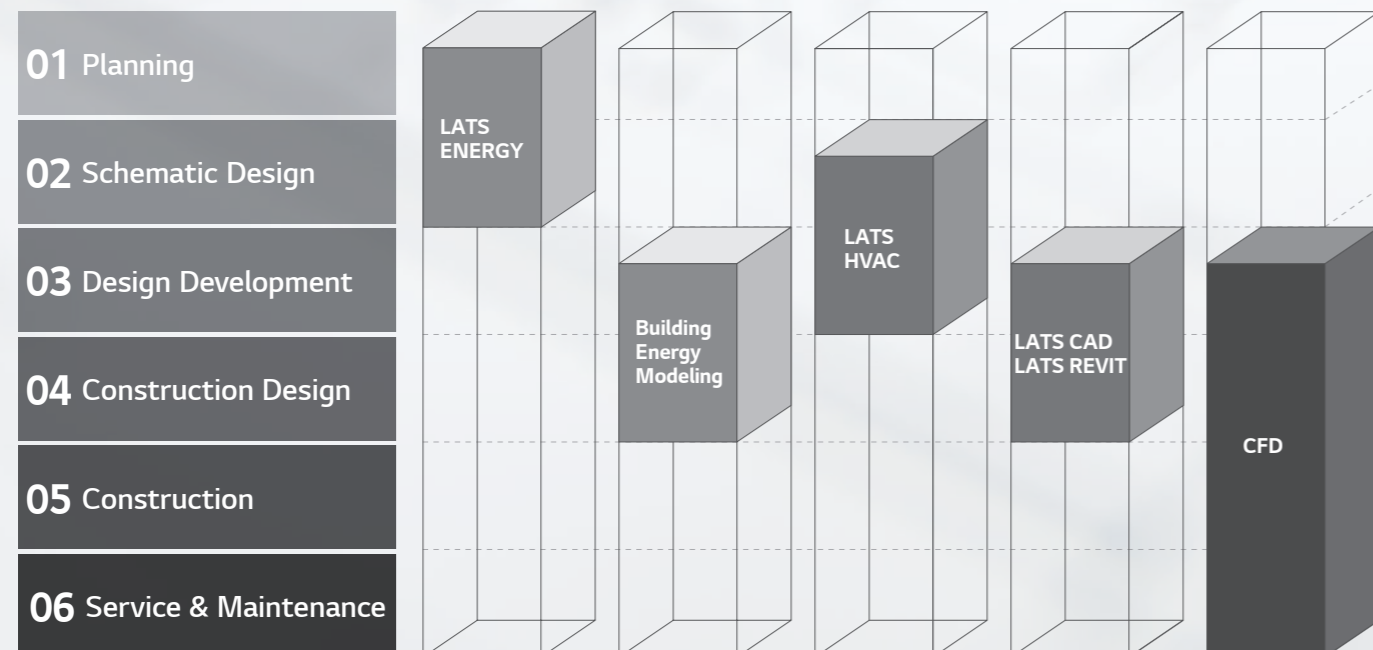

01 Draft Energy Estimation

LATS Energy

LATS Energy program is a draft energy estimation program, self-developed by LG. This program helps estimate the draft energy usage and analyzes the life cycle cost of LG VRF models during the early stage of a project.



02 Building Energy Modeling

eQuest, EnergyPro, Trace700 and More

These are certified commercial programs which assess the HVAC system efficiency and building's annual energy saving for building standard or certification like LEED. LG HQ supports these programs for the project stages of Design Development and Construction Design wherein the overall designing is finished.

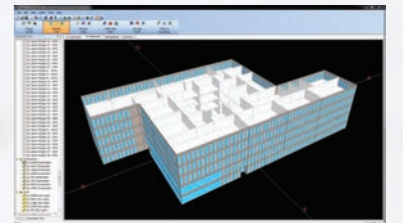

03 Model Selection

LATS HVAC

LATS HVAC is an integrated model selection program of LG HVAC products, enabling an accurate and quick selection on the best model suitable to each sites. In addition to model selection, faster estimation on refrigerant piping diameter and additional refrigerant is possible, along with auto printing of reports.



04 Design

LATS CAD

LATS CAD enables faster and a more accurate design of LG HVAC products. Moreover, it offers not only designing, but also quotation and installation review in order to minimize problems during installation processes.



LATS Revit

LATS REVIT is developed to make 3D designing of LG HVAC products easier than the previous program. It enables engineers to check 3D images from designing stage and prevents possible issues of the installation stage.

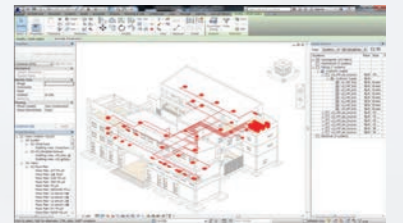

05 Installation Environment Simulation

CFD Analysis

CFD Analysis is applied in areas of estimating: indoor airflow and temperature distribution while operating VRF products, outdoor airflow distribution, and noise level. By running a simulation before construction, engineers estimate possible issues and find optimal solutions of malfunction that could occur after construction

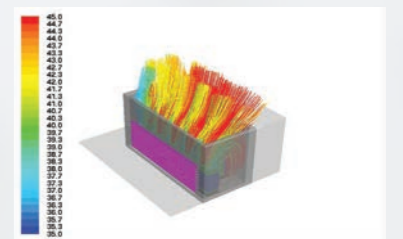

LG CONTROL SOLUTION

MULTI V 5 offers diverse range of effective control solutions that satisfy specific needs of each building and its user scene. These controlling systems are equipped with user friendly interface, flexible interlocking environment, energy management and smart individual controller for optimized controlling conditions and smart building management.

Hotel

Hotel Room Solution



Office

Central Control Solution



3rd Party BMS

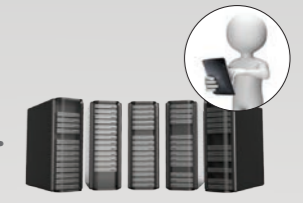
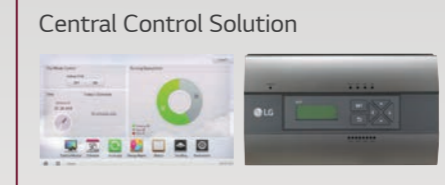

Service/Maintenance

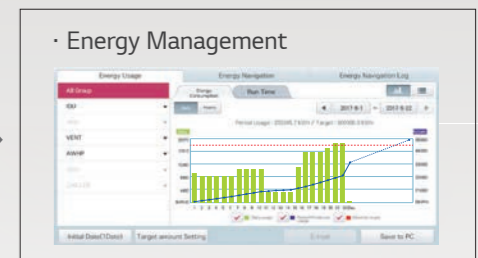

Energy Management

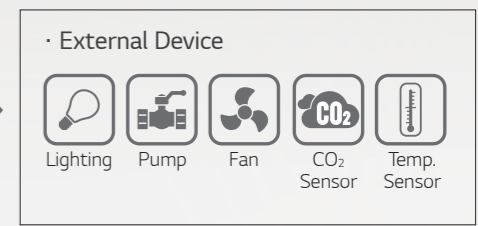

External Device



92kW



20kW



50kW

Apartment

Power Distribution Solution



Residential

Smart Individual Control Solution

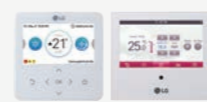

Small Building

Small Central Control Solution



Integration Solution



MULTI V™

BRAND HISTORY

From the moment when LG introduced Korea's first residential air conditioner in 1968, the company has continuously enhanced its technological innovation and credibility. As a result of sustained improvement, LG VRF launched the first generation of MULTI V in 2006 and achieved significant development. With world's top class compressor and innovative technology competency applied on every part, cycle and controlling solutions, it has evolved to be one of the world's most efficient and reliable VRFs.

Following the first and second generations with Inverter technology and non-ozone depleting refrigerant, MULTI V III has advanced its efficiency with diverse cutting-edge technologies such as HiPOR™ that directly returns oil to compressor and Vapor Injection that allows double compression by adding mid-pressure refrigerant. As acknowledged by the Eurovent Certification, the innovative technologies of 4th generation secured MULTI V brand the product leadership based on efficient system like Smart Load Control that controls operational load according to external temperature and other technologies that are optimized to manage refrigerant and heat exchange for all cooling, heating and part load operations. Moreover, MULTI V developed wide range of VRF line-up that could satisfy various types and size of building; MULTI V S is the VRF with side discharge, designed for small to mid-sized building and MULTI V WATER is the water-cooled VRF solution with variable water flow controlling technology.

In 2017, finally, the time has arrived for the ultimate VRF system, MULTI V 5. This generation has fully improved its technological potential with ever powerful and reliable yet economical LG's Ultimate Inverter Compressor, Ocean Black Fin with the most effective corrosion resistance performance and biomimetics technology-applied, enlarged fans. At the same time, the Dual Sensing Control offers users the most pleasant environment while minimizing the unnecessary energy loss with system that senses both the temperature and humidity to efficiently manage cooling, heating and part load operations.

With MULTI V 5 that has been solely designed for the ultimate efficiency, performance, flexibility, comfort and control, we are highly confident to bring the ultimate pleasant air experience.



2017
MULTI V™ 5



- Dual Sensing Control
- Ultimate Inverter Compressor
- Large Capacity ODU with Biomimetics Technology Fan
- Continuous Heating
- Ocean Black Fin

2006
MULTI V™

- Ø7.0 Corrugate
- Fuzzy Algorithm
- AC Inverter
- R410A

2008
MULTI V™ II

- Heat Recovery
- Ø7.0 Wide louver
- Fuzzy Algorithm
- LGDC Inverter

2010
MULTI V™ III

- High Pressure Oil Return
- Vapor Injection
- Continuous Heating

2013
MULTI V™ IV

- Eurovent Certification
- Active Refrigerant Control
- Variable Heat Exchanger Circuit
- Smart Load Control
- Smart Oil Return
- Vapor Injection (Advanced)

DUAL SENSING CONTROL

The cooling load is mainly based on the amount of both sensible heat load and latent heat load. Most importantly, the cooling load is keen to, and thus, greatly affected by external humidity, rather than the outdoor temperature. For such reason, Dual Sensing Control of MULTI V 5 senses both temperature and humidity and applies sensed data for load control in order to obtain in-depth understanding of sensible heat load and latent heat load. This helps preventing excessive cooling load supply and eventually offers the most pleasant and comfortable cooling environment the users want with reduction in energy consumption.

Previous VRF : Single Sensing



DID YOU KNOW THAT VRF UNTIL NOW HAS ONLY SENSED SINGLE INFORMATION?



MULTI V™ 5 : Dual Sensing



Smart Load Control (SLC)

This comprehensive understanding of environmental conditions allows optimized energy efficiency and maximized indoor comfort level.

ESEER
Up to 21%
(vs. standard mode at 2.6HP)

Comfort Cooling

This maintains operation at mild cooling mode around set temperature without stopping in between operations for maximized user comfort.

Improved Indoor Comfort

ULTIMATE INVERTER COMPRESSOR



As the core technology of the air conditioning system, the Ultimate Inverter Compressor of MULTI V 5 boasts its ultimate efficiency and durability, designed based on the unique technology and innovation of LG HVAC.

10% IMPROVED ENERGY EFFICIENCY ENHANCED COMPRESSOR RELIABILITY

All Inverter

Provide high efficiency with low vibration and low noise

Six By-pass Valves

Prevent compressor damage due to excessively compressed refrigerant more efficiently than 4 by-pass valves

01. Vapor Injection

Maximize heating capacity via two-stage compression

02. Enhanced Bearing with PEEK Material

Newly invented system motivated by PEEK (Polyetheretherketone) bearing used for aero engine to increase operation range and durability

03. Wide Operation Range from 10 to 165Hz

Improved part load efficiency at all operation ranges

04. HiPOR™ (High Pressure Oil Return)

Resolve compressor efficiency loss caused by oil return

05. Smart Oil Management

Oil level detection in real time

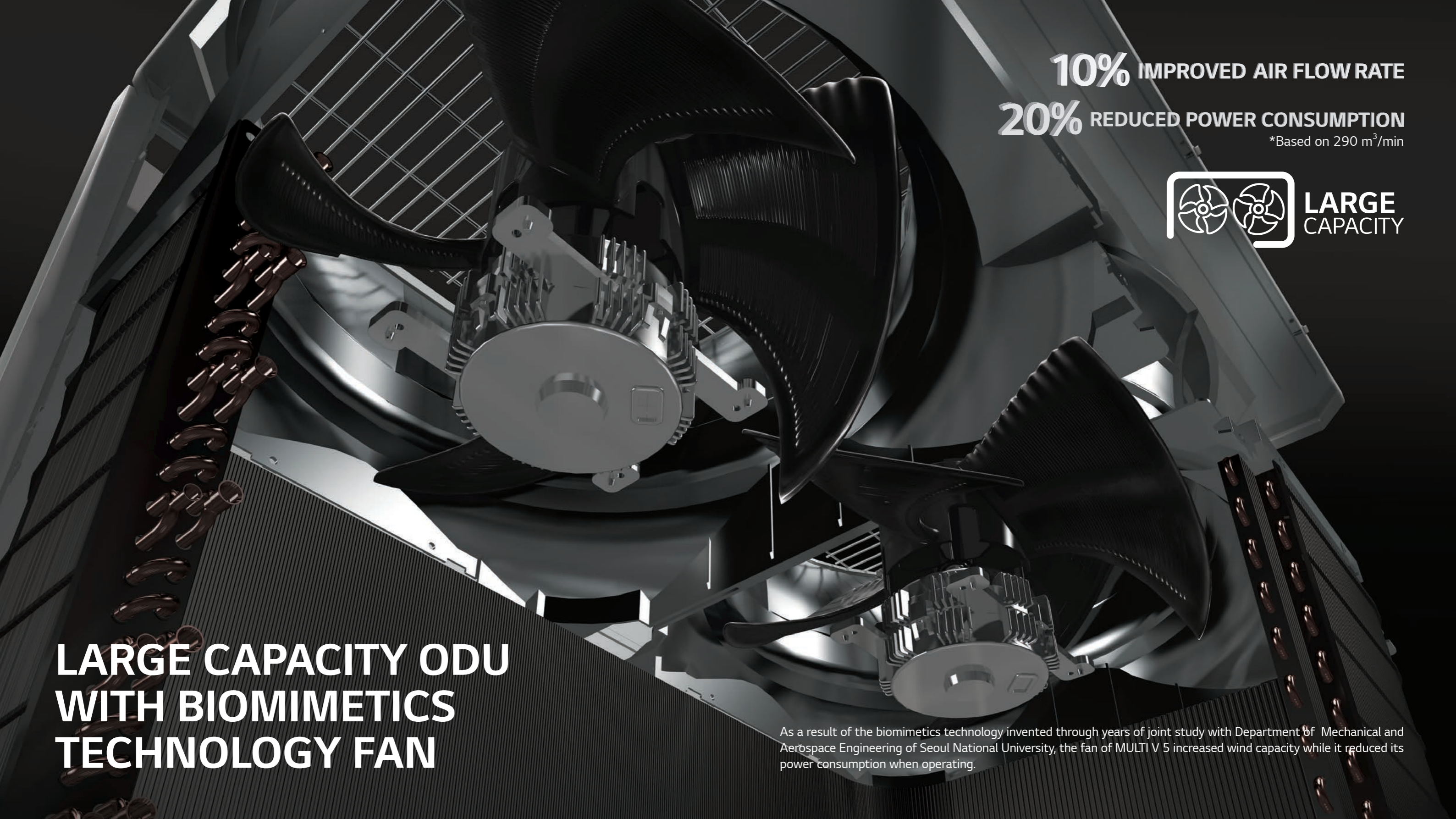

10% IMPROVED AIR FLOW RATE
20% REDUCED POWER CONSUMPTION
*Based on 290 m³/min



LARGE CAPACITY ODU WITH BIOMIMETICS TECHNOLOGY FAN

As a result of the biomimetics technology invented through years of joint study with Department of Mechanical and Aerospace Engineering of Seoul National University, the fan of MULTI V 5 increased wind capacity while it reduced its power consumption when operating.



Humpback Whale Design

Inspired by the bumps on the humpback whale's flipper, the tubercles on the back side increased wind power by reducing flacking.



Clam Shell Pattern

Like the clam shell textures, the range difference created by moire pattern reduced noise level.



Increased Air Flow Rate

With extended shroud, discharged air current is stabilized and power consumption is reduced.

Large Capacity Outdoor Unit

Enhanced core parts like biomimetics technology-based fans, 4-sided heat exchanger as opposed to 3-sided heat exchanger of previous model and compressor with increased efficiency and capacity allow large capacity for outdoor units. A single unit of MULTI V 5 can provide up to 26HP.

OCEAN BLACK FIN HEAT EXCHANGER

LG's exclusive "Ocean Black Fin" heat exchanger is specially designed for durable and long-lasting performance even in corrosive environments. The black coating is applied for protection from various corrosive external conditions and the hydrophilic film keeps water from accumulating on the heat exchanger's fin, minimizing moisture buildup. This improvement in durability prolongs the product's lifespan and lowers both the operational and maintenance costs.

Ocean Black Fin

CERTIFICATE OF VALIDATION

Certificate Number / Report Reference: 47887353204 / 47887553204-01
 Issue Date: 2018-04-25
 Expiration Date: 2018-04-24
 Issued to: LG Electronics Inc.
 76 Seongsan-dong, Changwon-si, Gyeongnam, 641713, Korea

UL

Claim Validated: Aluminum Fin & Copper Tube Heat Exchanger employed on the Outdoor Unit of Air-Conditioners. Simulating the corrosive test for 27 years of exposure in a more severe traffic environment with salt contamination (Test Method B).

Test: Test method B of ISO11207 - Salt contaminated condition + severe industrial or traffic environment.

Standards / Regulations: ISO 11207, IEC & Annex A, LG-004-014

This certificate and the data validation results on the specimen described above, shall be the data based on the criteria defined by the client. Client's use of the validated data on or in connection with the product is and shall remain Client's responsibility that the item is true and accurate. UL neither warrants the sample for replacement neither the sample nor replacement of production units. The test results shall only be the actual results. UL is not responsible for the quality of the test performed or for the accuracy of test data generated by third parties. Please see test report for full details.

This certificate is not a UL Listing, Classification or Recognition or other certification by UL, and does not authorize the use of UL Listing, Classification or Recognition Marks on or in connection with the product. The validated data shall be used to predict performance and in no way, direct or indirect, shall be used to certify the safety of the product described above.

Chunhee Kim
 Engineering Leader
 Component & Material
 LG Korea Ltd.
 300 W Corporate Plaza, Seoul, 137
 Yongsan-gu, Gangnam-gu, Seoul, Korea

* Test Method B Simulation Validated
 (Test condition: Salt contaminated condition + severe industrial/traffic environment (NO₂/SO₂))
 * Based on 1,500 UL test hours

CONTINUOUS HEATING



Improved technologies such as Dual Sensing Control, Partial Defrost and Smart Oil Management enhance Continuous Heating for increased heating capacity and indoor comfort. The delayed and partial defrost technologies minimize unnecessary operational consumption to provide consistent heating.

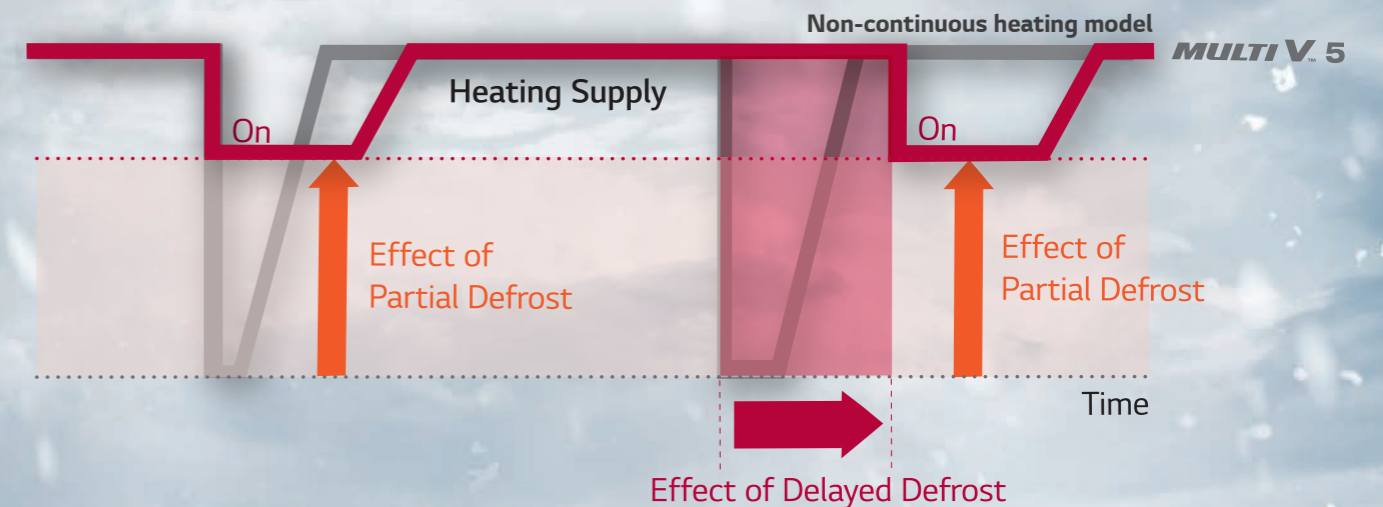

↑ Heating Operation Time Per Day Up to 11%
 ↓ Power Input Down to 7%

* LG internal test result
 * Test condition : Outdoor 2/1°C, Indoor 20/15 °C, Humidity 83%



Dual Sensing Control



Partial Defrost



Smart Oil Management

MULTI V 5 FOR CONSULTANTS & HVAC DESIGNERS

From accurate 3D-based building modeling to strong system capability regardless of the building size and climate conditions, MULTI V 5 offers the most efficient and flexible installation environment for consultants and HVAC designers. Indeed, MULTI V 5 is the most reasonable HVAC system that has achieved the best efficiency through LG's enhanced inner parts, operational cycle and controlling technology.

01 Improved designing effectiveness and accuracy via LATS Revit, the BIM application

LG provides 3D-based BIM simulation tool, LATS Revit, in order to offer product selection, positioning and piping from installation, interference check to correction phases based on systematic consideration of the load. This enables the easiest, yet the most accurate system modeling support.



02 Applicable to various climate conditions and purposes based on wide operational range for both heating and cooling operations

Even in the extreme climate situations, MULTI V 5 can perform stable heating and cooling operations. Due to LG's improved inner parts and cycle technology, it can perform heating operation at extremely cold temperature as low as -25°C. For cooling performance, MULTI V 5 can operate from -15°C to 48°C. With wide operational range, it can perfectly perform heating operation in cold environment, making the product adequate for uses in specialized venues like server rooms.

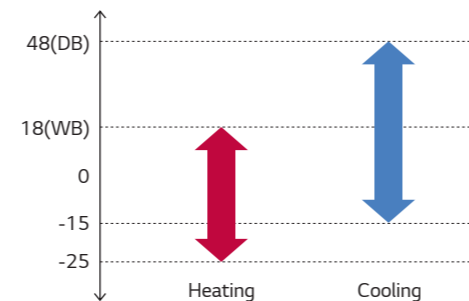

03 Flexible construction design available due to long piping technology

Through the world's best class piping technology MULTI V 5 provides the perfect solution for various types of building with diverse size and purposes. The longest piping length offered by MULTI V 5 is 225m and height difference between outdoor unit and indoor unit stretches up to 110m.

Total Piping Length	1,000m
Actual longest piping length	225m
Longest piping length after 1 st branch (conditional application)	40m (90m)
Height between ODU - IDU	110m
Height between IDU - IDU	40m
Height between ODU - ODU	5m

04 The most economical solution with the world's top class energy efficiency

Improved reliability based on LG's Ultimate Inverter Compressor and other core parts, as well as the most developed controlling technology due to optimal cycle operation and Dual Sensing Control that recognizes both the temperature and humidity achieved the world's best class seasonal efficiency (ESEER) of 9.15. As a result, this enables the most economical system capability for MULTI V 5 in comparison to any other existing HVAC systems.

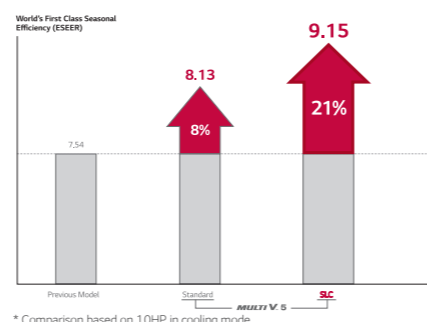

* Comparison based on 10HP in cooling mode

INSTALLERS

Due to increased capacity provided by single outdoor units, installation became simpler with reduced number of outdoor unit combination. Moreover, solutions connected to and operated by smart devices significantly shortened physical hours required for test run, diagnose and monitoring of multiple services while making these controlling more accurate.

01 Increased installation convenience due to large capacity units reducing number of outdoor units required for combination

By providing up to 26HP for single unit line up, MULTI V 5 decreases the total number of required outdoor units in order to ultimately simplify installation process, when compared to previous models. For example, previous system required a combination of a 20HP outdoor unit, a 18HP outdoor unit and a 10HP outdoor unit to run a total of 48HP. For MULTI V 5, however, only 2 outdoor units with each providing 24HP can cover the same amount. This significantly reduces installation hours, especially those that used to take long time such as using crane to properly place outdoor units on the rooftop.

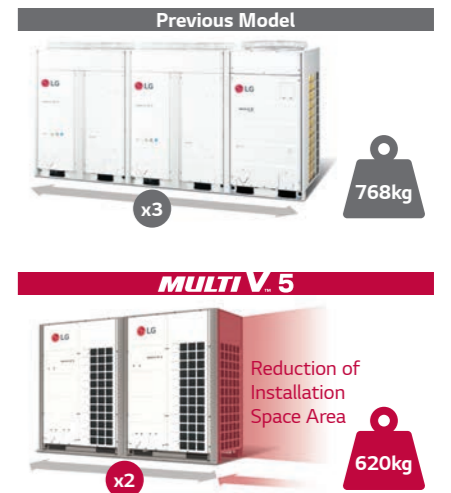

02 Simple and easy installation and service with Mobile LGMV

With LGMV, the smarter SVC application, hours and resources spent for installation are significantly reduced and more accurate installation and service can be offered.

Auto test run

Mobile application allows automatic address setting and test run report releasing.

Refrigerant diagnose solution

By regularly checking the amount of refrigerant, it automatically reloads if current amount is not enough.

Easier setting for installers

Unlike before when set up had to be done via DIP Switch of Outdoor unit, installers can simply manage setting via mobile app for MULTI V 5. Indeed, settings for SLC steps, Dual Sensing Control and outdoor unit fan's maximum RPM control can be easily managed via LGMV.

Smart management

By checking test run history, black box review and other previous records, site information can be managed efficiently.

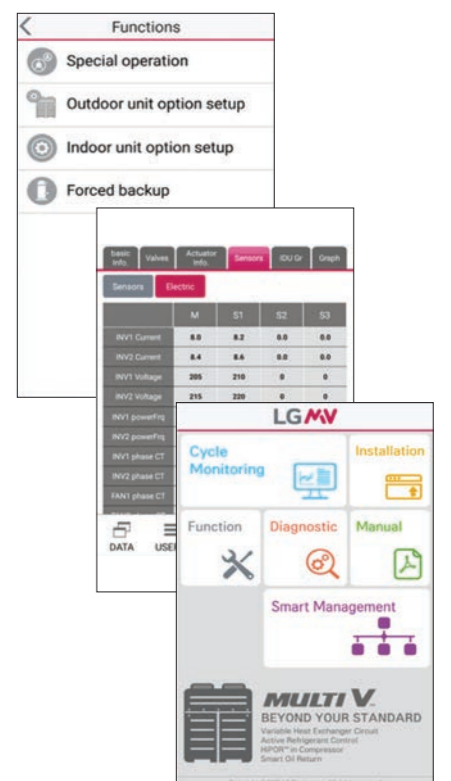

BUILDING OWNERS

With increased reliability of core parts such as compressor and heat exchanger, as well as high operational efficiency, building owners can significantly reduce operational costs in comparison to other systems. At the same time, large capacity outdoor units minimize installation space which eventually allow better use of the floor space. Moreover, MULTI V 5 prevents overuse of the operational costs by planning and consuming the projected monthly energy usage.

01 Corrosion resistance via Ocean Black Fin

Protection certified by UL (Underwriters Laboratories), LG's exclusive Ocean Black Fin is applied on the heat exchanger of MULTI V 5 in order to perform even in corrosive environments. The protection from various corrosive external environments such as seaside with high salt contamination and industrial cities with severe air pollution caused by fumes from factories keeps MULTI V 5 operating without breakdown.



02 Minimized installation footprint via large capacity outdoor units for flexible usage of the saved floor space

MULTI V 5 provides up to 26HP for single unit line up. Considering that a total of 260HP is being installed, the total installation space is saved up to 23% while the overall product weight decreases up to 15% in comparison to previous model. This eventually resulted in the maximized use of the saved floor space. Moreover, reduced product weight of MULTI V 5 makes installation easier with less limitation on product weight installed on the building's rooftop.

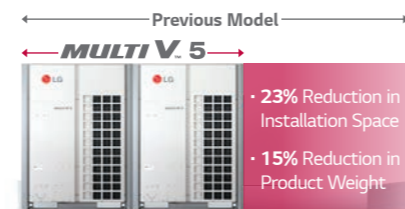

03 Operational costs management by presetting energy consumption

Energy management function allows MULTI V 5 to preset monthly energy usage and consume what has been previously planned. By analyzing and comparing previous consumption and planned energy usage for the month, overuse of the HVAC system operational costs can be prevented.

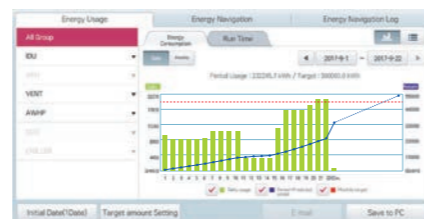

04 Easy building remodeling with Integral system that offers both the Heat Pump & Heat Recovery

MULTI V 5 offers HVAC solution with integrated system that offers both the Heat Pump and the Heat Recovery Systems. Even if the site has been previously installed with Heat Pump System, user can easily replace it with Heat Recovery System or Hot Water Solution when necessary, through simple piping construction which eventually allows more rooms for future remodeling plans.

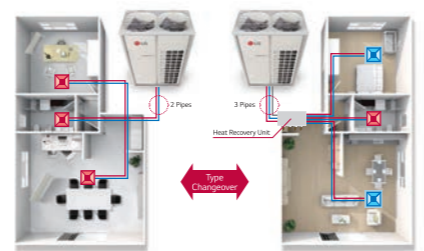

Heat Pump System | Heat Recovery System

END USERS

LG's inverter technology and capability to actively respond to the building's both internal and external environment allow users to quickly arrive at the desired ambient and systematically maintain such condition. Moreover, users can control the indoor environment remotely via smartphone from wherever and whenever. Lastly, new Standard III Remote Controller with simple user interface and premium design provides users the optimal controlling experience.

01 More comfortable cooling operation via Dual Sensing Control

With the performance of LG's Ultimate Inverter Compressor MULTI V 5 can quickly approach at user's desired temperature. At the same time, Dual Sensing Control manages and maintains indoor temperature pleasantly based on its recognition of both the temperature and humidity in order to offer the optimal user comfort.

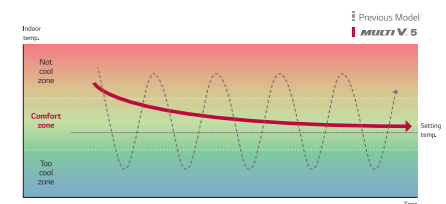

02 Continuous heating operation

Due to improved technologies of MULTI V 5 such as delayed defrost via Dual Sensing Control, partial defrost and smart oil management, users can enjoy pleasant and comfortable indoor environment with no stopping of heating operations in between.



03 Optimal controlling environment with new Standard III Remote Controller

MULTI V 5's new wired remote controller offers simple and easy controlling experience via simplified user interface and 4.3-inch large colored LCD screen. Moreover, it provides diverse information such as indoor temperature, humidity, cleanliness and real-time check on energy consumption.



MULTI V 5 Certified to Meet New EUROVENT Efficiency Regulations

The MULTI V range has always been at the forefront of energy efficiency. LG takes customers' concerns about energy savings very seriously. The company also strives to protect the environment by continuously improving MULTI V technology, thereby reducing its carbon footprint.

In European Union countries, the energy efficiency of variable refrigerant flow (VRF) products has become a policy of its own. While European policymakers encourage technology improvements of VRF products, they also recently set minimum efficiency boundaries. This is to ensure that less energy-efficient VRF products are no longer sold, while environmentally friendly VRF units are promoted. As a result, beginning in 2018, VRF products will have to meet minimum energy efficiency standards, also taking into account the seasonal operation of the product in both heating and cooling modes.

Preserving the environment is LG's top priority, and MULTI V 5 will meet the stricter efficiency standards from day one. As a company, LG is pleased that mandatory regulations on energy efficiency will allow easier comparisons between manufacturers offering similar products. Efficiency assessments will be done on an equal footing, thus allowing customers to make informed choices measured according to European regulations and standards. However, LG's transparent communication regarding the energy performance of

MULTI V 5 units does not stop there. MULTI V 5 will also have its performance certified through independent third party organizations, such as Eurovent certification for VRF.

MULTI V 5 performances will be assessed and certified so LG customers will be able to make the most of national incentive policies that require certified data when implementing VRF technology. Eurovent certification for MULTI V 5 will allow customers to accelerate their business and to reduce their workload to minimal levels. Eurovent certification for MULTI V 5 will be even more important as the EU rules for the energy efficiency of VRF products do not require energy labeling to be displayed with the units. However, designers and construction companies consulting the Eurovent database will find information about the energy performance of MULTI V 5 at a glance.



5 MAIN FEATURES

28 / ULTIMATE EFFICIENCY

36 / ULTIMATE PERFORMANCE

42 / ULTIMATE COMFORT

45 / ULTIMATE FLEXIBILITY

48 / ULTIMATE CONTROL

53 // HEAT RECOVERY



ULTIMATE EFFICIENCY

MULTI V 5 ensures world's best class energy efficiency with innovative technology including the LG's Ultimate Inverter Compressor.

LG's Ultimate Inverter Compressor

The newly designed bearing of the Ultimate Inverter Compressor allows low-frequency operation at 10 Hz from the previously lowest speed at 15 Hz, increasing the ultimate efficiency and reliability of MULTI V 5.



Vapor Injection

- Maximize heating capacity via two-stage compression
- Provide powerful heating in low temperature conditions
- Improve energy efficiency and heating performance

Enhanced Bearing with PEEK Material for Increased Durability and Reliability

- Applied newly invented scroll system driven by PEEK (Polyetheretherketone) bearing used for aero engine
- Can operate longer without oil supply
- Increase durability and reliability

Extended Compressor Speed from 10 Hz

- Increase part load efficiency at all operation ranges
- Rapid operation response
- Capable of reaching required temperature quickly

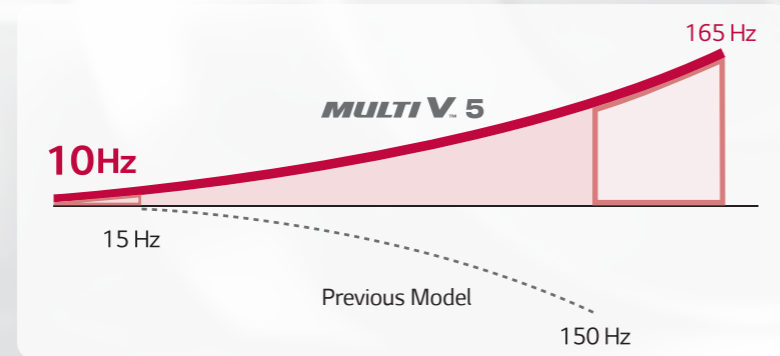

Concentration Motor

- 10% increase of magnetic flux density

HiPOR™

- Minimizing energy loss with direct oil return

Smart Oil Management

- Measuring the presence of oil through the oil sensor

ULTIMATE EFFICIENCY

World's First Class, Rated Efficiency (Eurovent Test Condition)

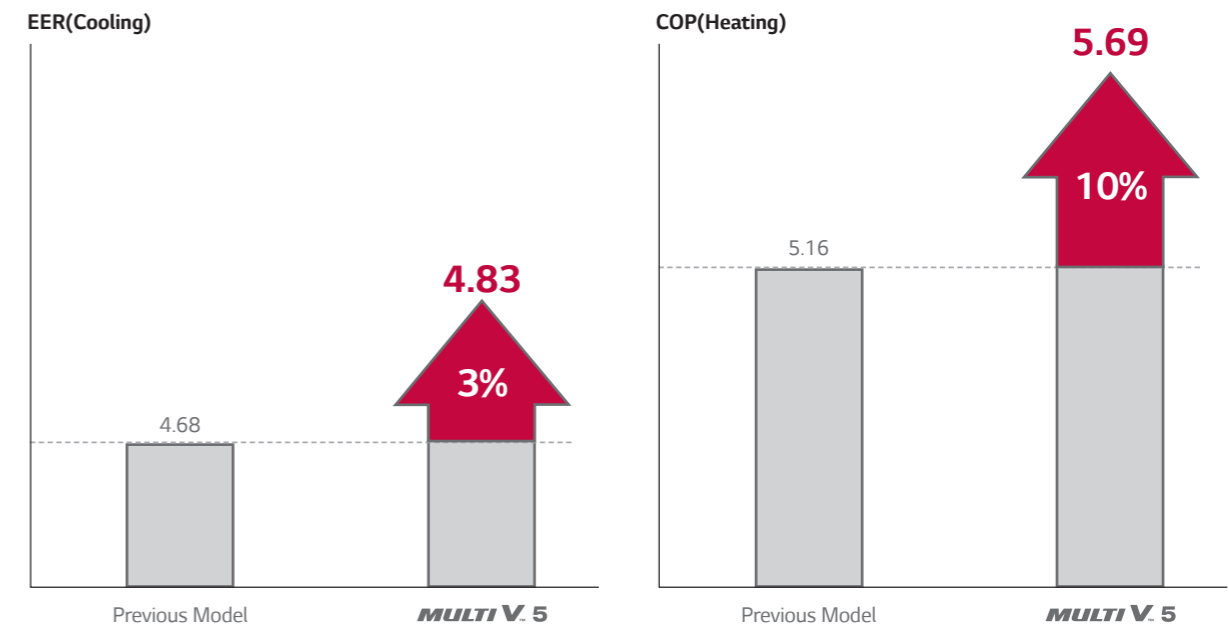

* Comparison based on 10HP in cooling mode

* Comparison based on 10HP in heating mode

World's First Class Seasonal Efficiency (ESEER)

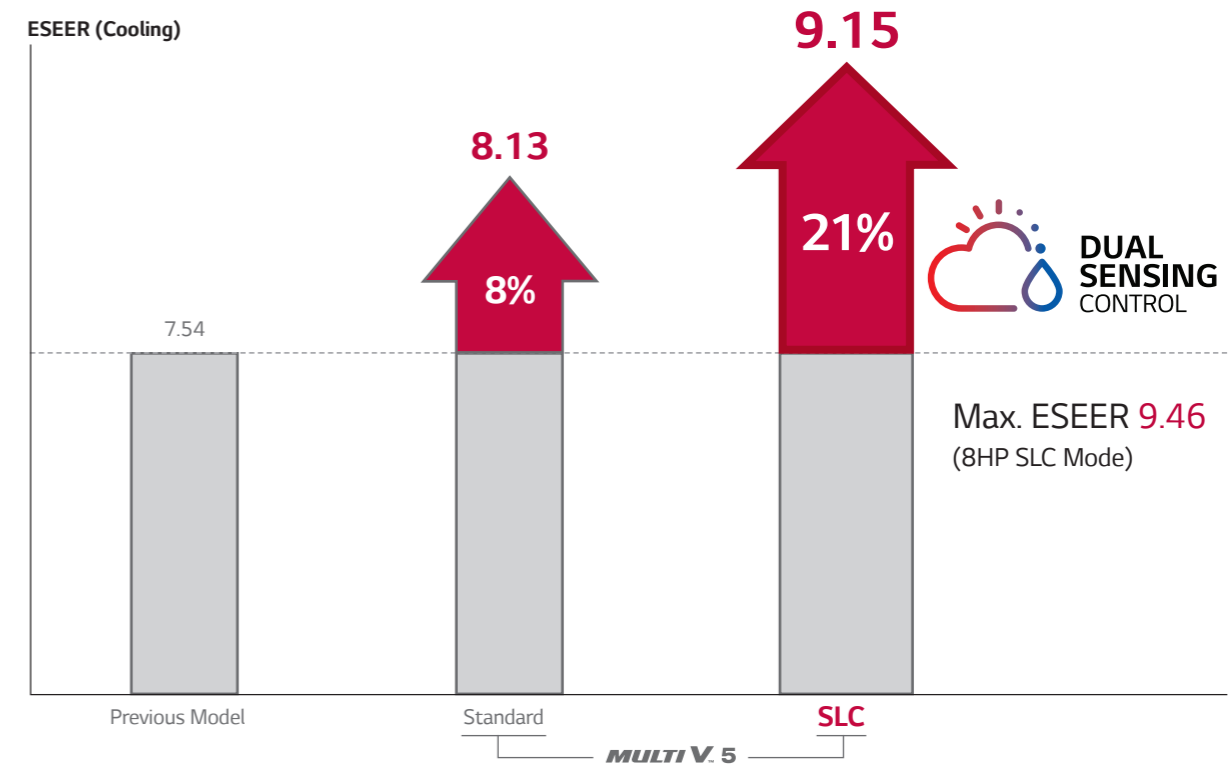

* Comparison based on 10HP in cooling mode

ULTIMATE EFFICIENCY

Smart Load Control (SLC)

Smart Load Control function enables comprehensive understanding of environmental conditions in order to optimize energy efficiency and maximize indoor comfort level. This technology allows active control of discharge refrigerant temperature which eventually increases the ESEER up to 21% for maximum 26 HP and 15% for average outdoor units in comparison to the previous models.



Increased Energy Efficiency(SLC ESEER)

Up to 21%

Up to 15% (High humidity) ~ **31%** (Low humidity)

For low temperature, lower load and capacity are required

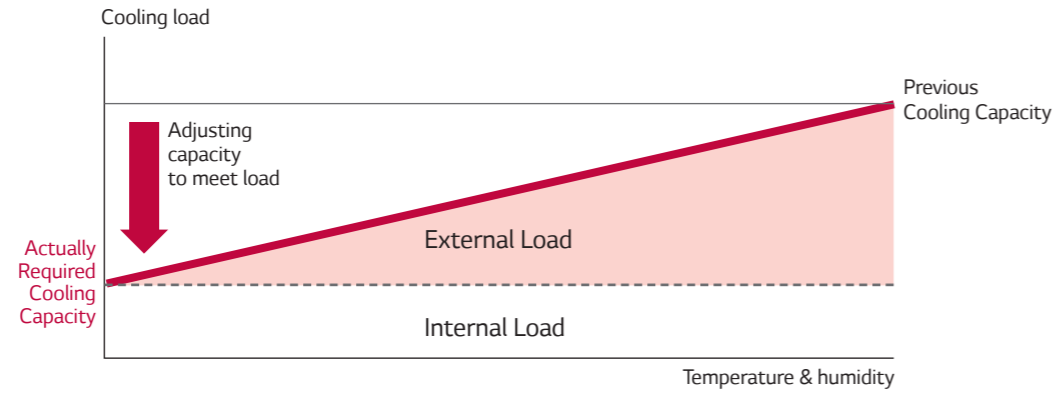

Lower load and capacity need higher evaporation temperature

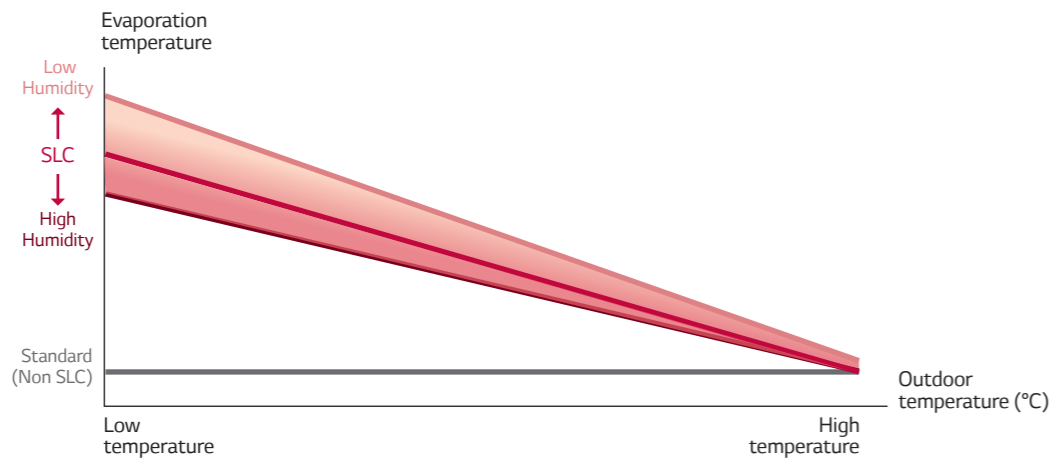

Higher evaporation temperature results in higher efficiency

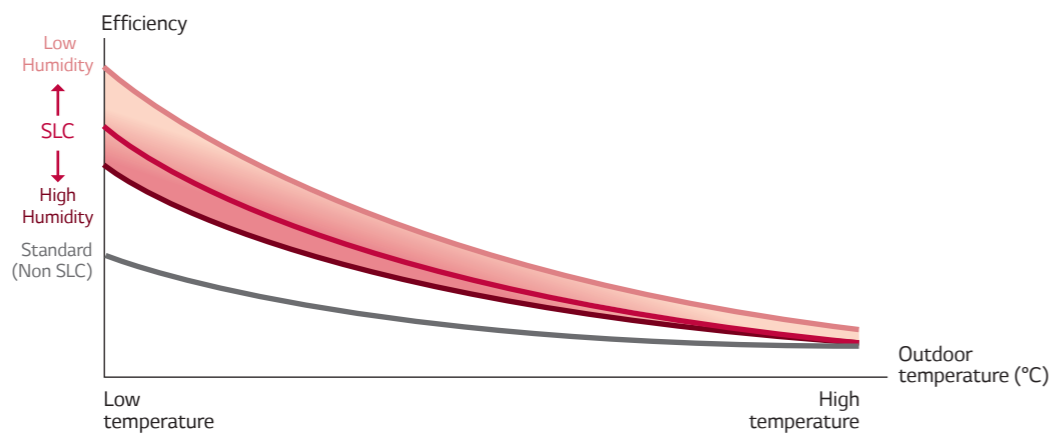

* Low humidity: Below 50% / Standard: 50~70% / High humidity: 70~100%
* Setting is available in indoor (Standard III Remote Controller)

HiPOR™ (High Pressure Oil Return)

HiPOR™ technology enables oil to return directly into the compressor, instead of returning through the refrigerant suction pipe in order to minimize energy losses while maximizing the efficiency of compressor.

The previous model compressor that caused loss of low pressure refrigerant return to the refrigerant pipe. However MULTI V 5 maximizes reliability and efficiency of the compressor by reducing high pressure refrigerant loss.

Process comparison

Non-HiPOR™ vs. MULTI V 5

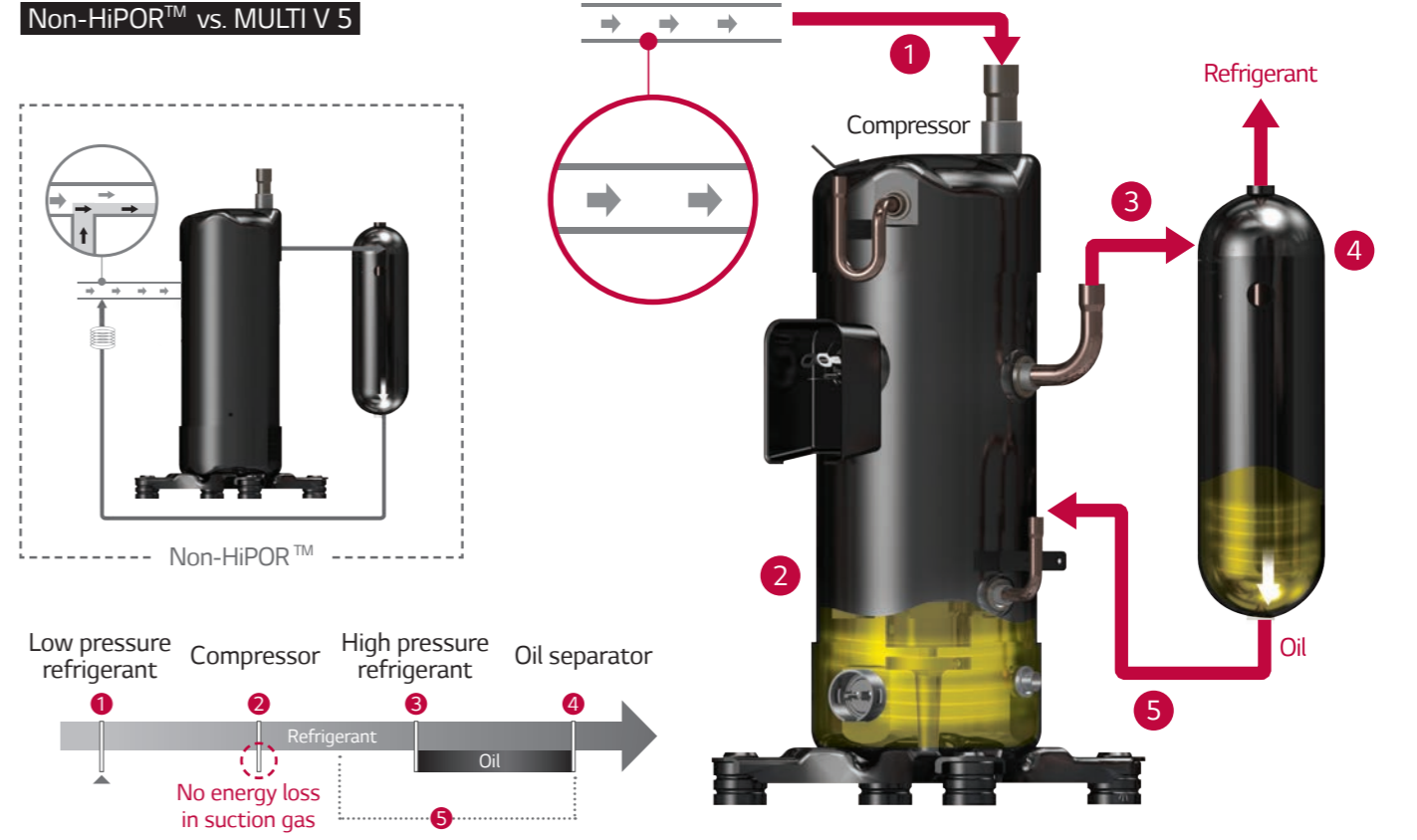

Efficiency comparison

Non-HiPOR™ vs. MULTI V 5

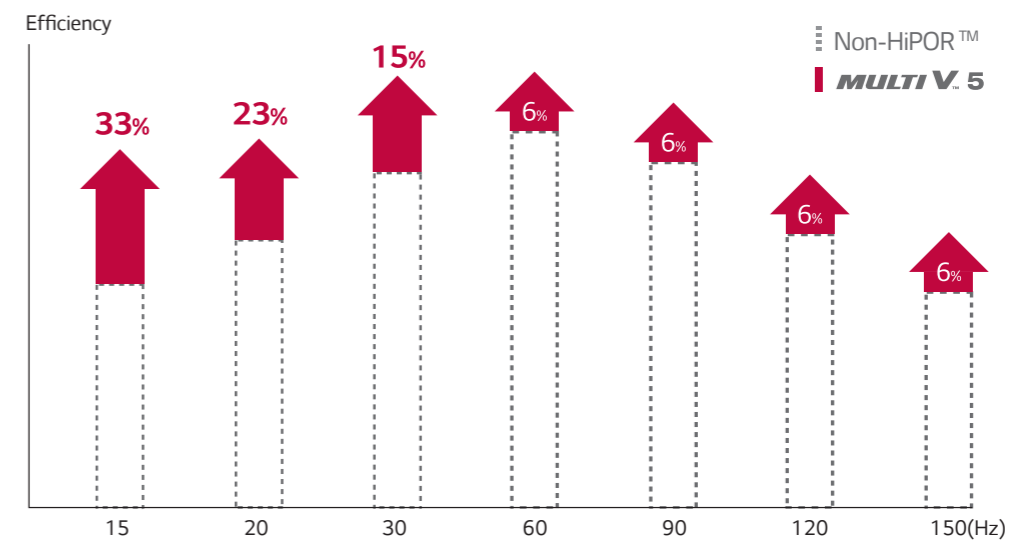

* Rating condition (Tc=54.4 °C, Te=7.2 °C)

ULTIMATE EFFICIENCY

Vapor Injection

Vapor Injection uses a two-stage compression effect, which is designed to provide efficient heating in very cold environments. Combined with HiPOR™, this system boosts heating performance and enhances heating temperature range.

Technology mechanism

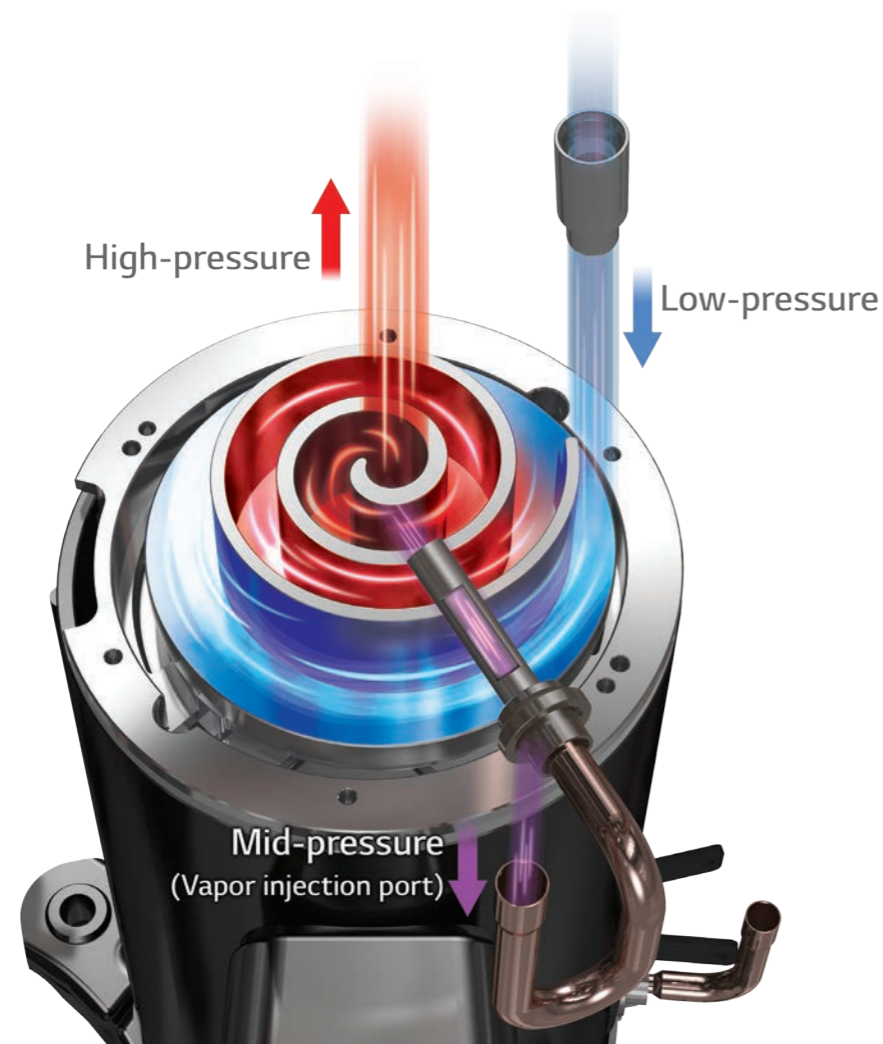

Performance comparison

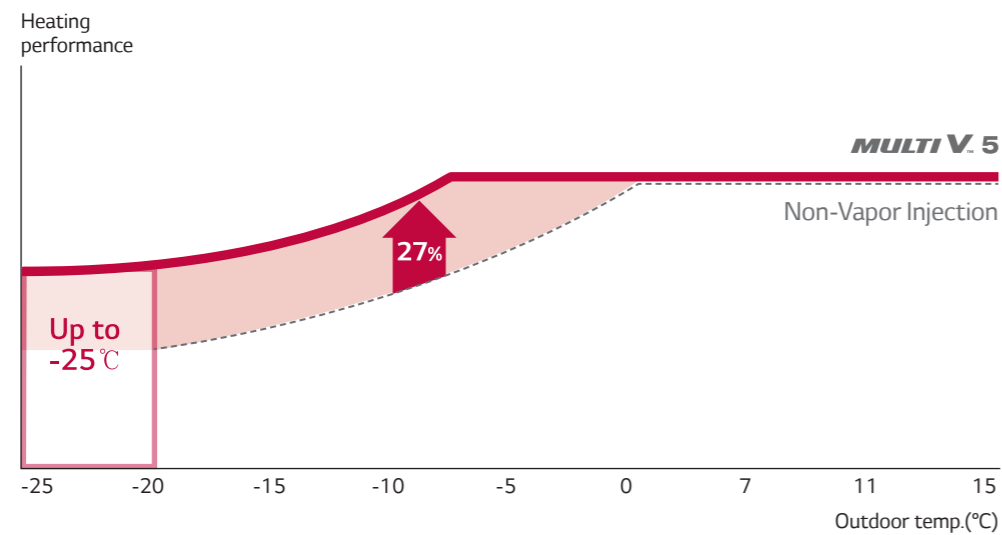

* Improved heating performance by 27%
* Comparison tested on 10HP model

Active Refrigerant Control

Active Refrigerant Control **monitors and adjusts the quantity of circulating refrigerant during each cycle to maximize efficiency** in real time when it runs cooling and heating operation, as well as the part load operation.

This five step control leads to an improvement in energy efficiency, unlike when fixed amount of refrigerant is provided to the compressor regardless of operation mode, which limits optimal efficiency for each operation.

Technology mechanism

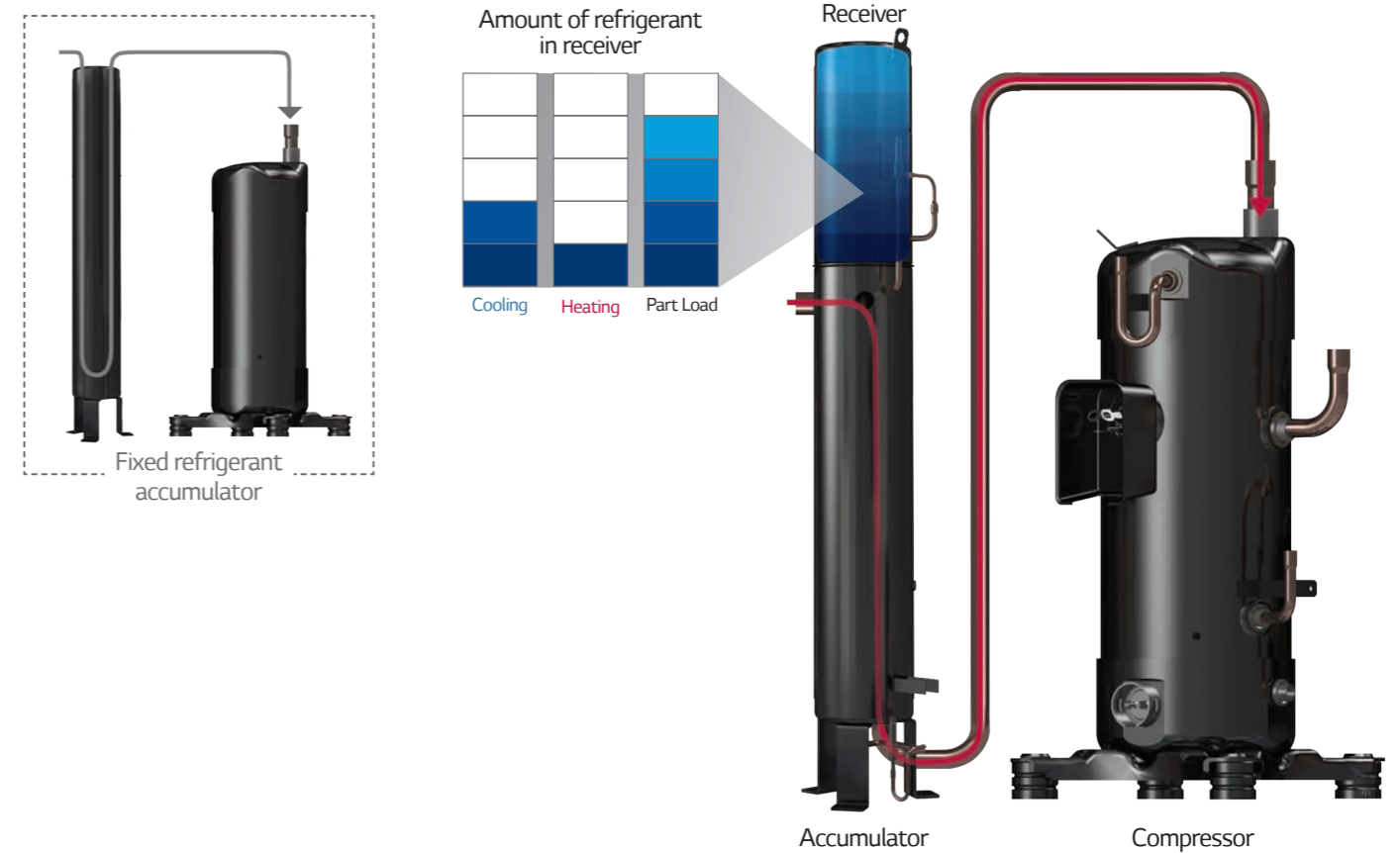

Efficiency performance

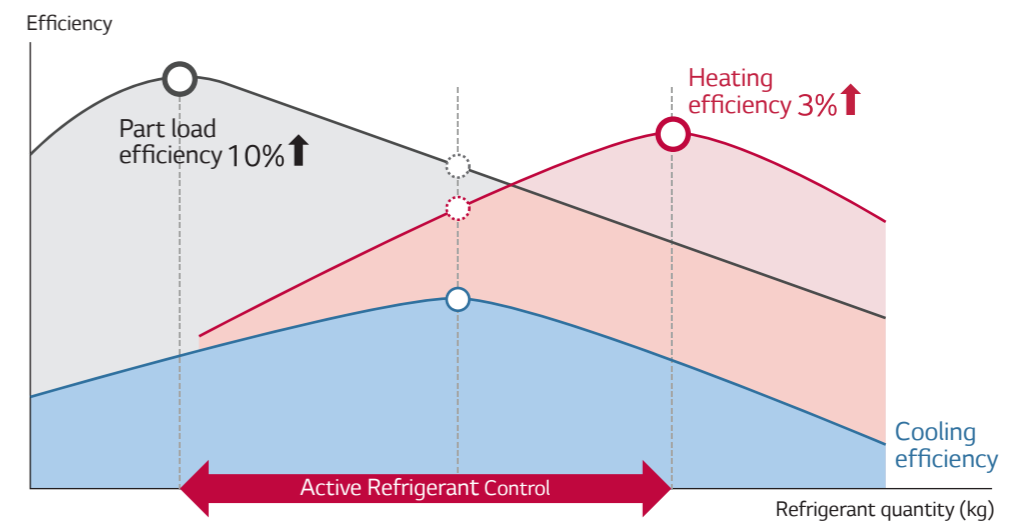

ULTIMATE EFFICIENCY

Smart Oil Management

Compressor reliability and Efficiency are improved with an oil sensor that allows oil balancing and oil return. The value of the capacitance between the electrodes can measure the presence of oil in real-time. **This real-time measurement of oil in the compressor reduces energy loss, providing consistent heating for the indoor environment.** With Smart Oil Return, heating operation time per day has increased up to 12% in comparison to previous model.

Auto Oil Balancing



Smart Oil Return

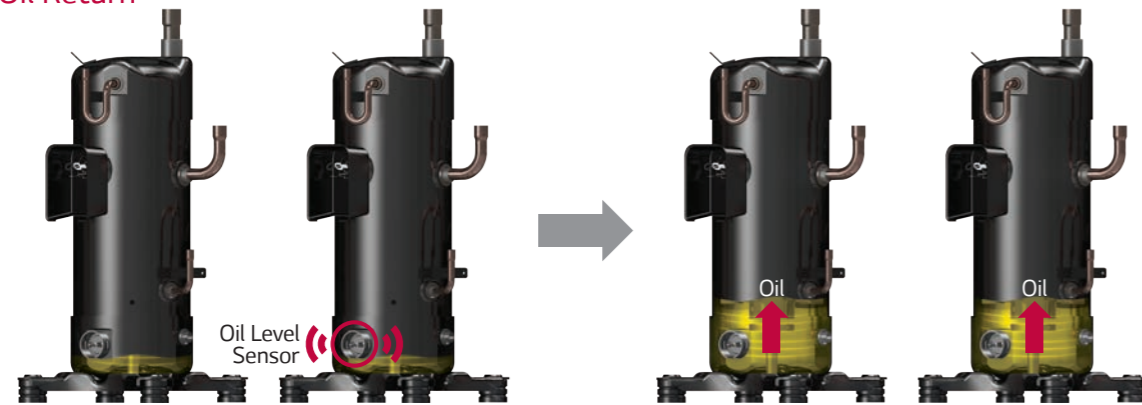

Variable Heat Exchanger Circuit

Variable Heat Exchanger Circuit intelligently **selects the optimal path for both heating and cooling operations.** With this smart path selection technology, an average of 6% increase in the efficiency of both operations has been achieved.

The **paths number and circuit velocity are adjusted to match temperatures and operation modes** in order to maximize efficiency instead of compromising efficiency for each operation when the number and direction of paths are fixed independently of temperature operation mode.

Technology mechanism

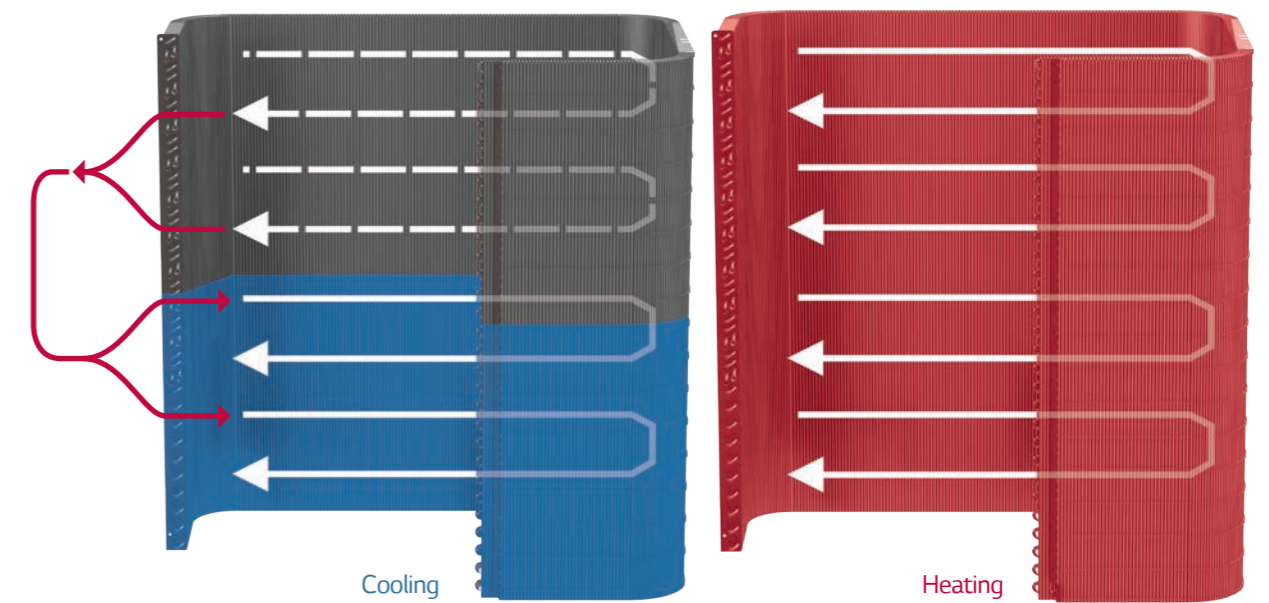
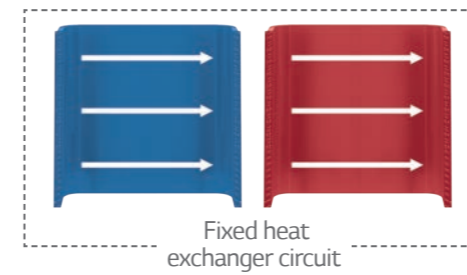

Operation time comparison

Non-oil sensor model vs. MULTI V 5

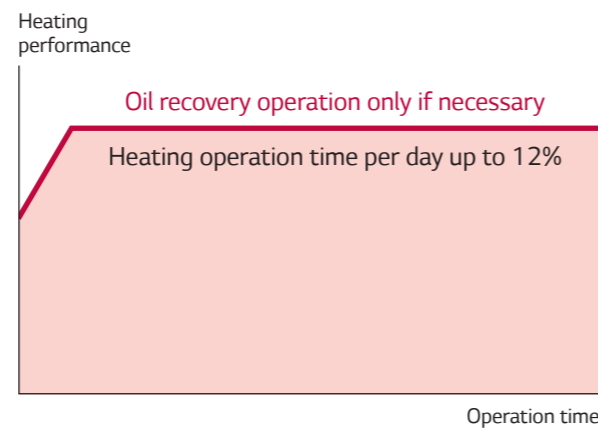
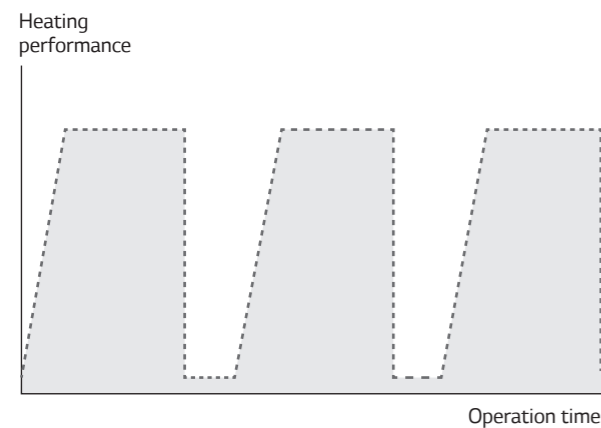

Efficiency performance

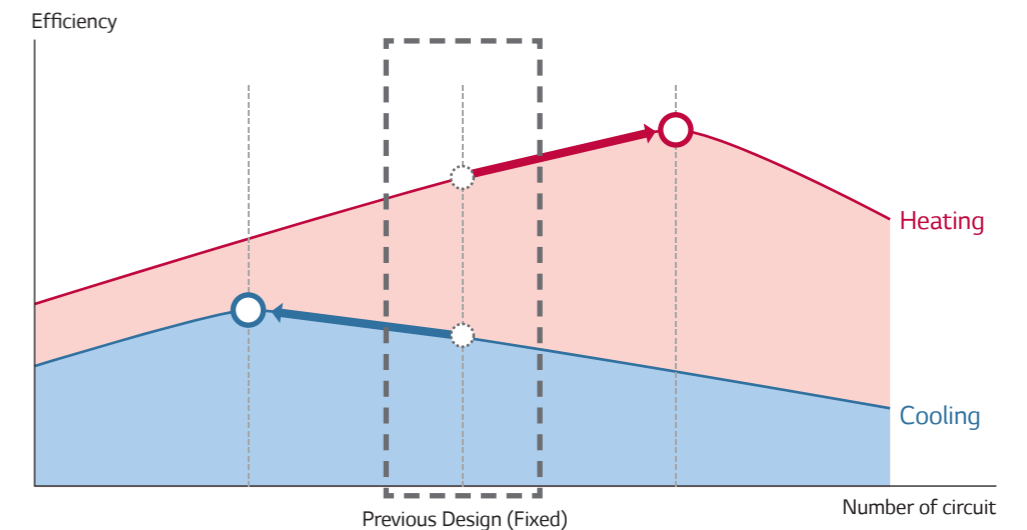

ULTIMATE PERFORMANCE

MULTI V 5 ensures ultimate reliability with Ocean Black Fin, large capacity fan and enhanced bearing system for the best performance across the various environments.

Heat Exchanger with Ocean Black Fin for Corrosion Resistance

LG's exclusive Ocean Black Fin is applied on the heat exchanger of MULTI V 5 in order to perform even in corrosive environments. The strong protection from various corrosive external environments such as seaside with high salt contamination and industrial cities with severe air pollution caused by fumes from factories keeps MULTI V 5 operating without breakdown. This improvement in durability prolongs the product's lifespan and lowers both the operational and maintenance costs.



ULTIMATE PERFORMANCE

Corrosion Resistance Proven by Certified Tests

LG Corrosion Resistance solution passed ISO accelerated corrosion test conducted by an independent test organization and the result has been certified by prestigious global certification organization, UL (Underwriters Laboratories).

Certified protection

Condition of salt spray test

Temperature	35°C
Mist of 5% sodium chloride solution	

Condition of gas exposure test

R.H.	NO ₂	SO ₂
95%	10 x 10 ⁻⁵	5 x 10 ⁻⁶



* Test Method B Simulation Validated
(Test condition: Salt contaminated condition + severe industrial/traffic environment(NO₂/SO₂))

* Based on 1,500 UL test hours

Enhanced Coating Layers

The black coating with enhanced epoxy resin is applied for protection from various corrosive external conditions such as salt contamination and air pollution including fumes from factories. Moreover, the hydrophilic film keeps water from accumulating on the heat exchanger's fin, minimizing moisture buildup and eventually making it corrosion resistant.

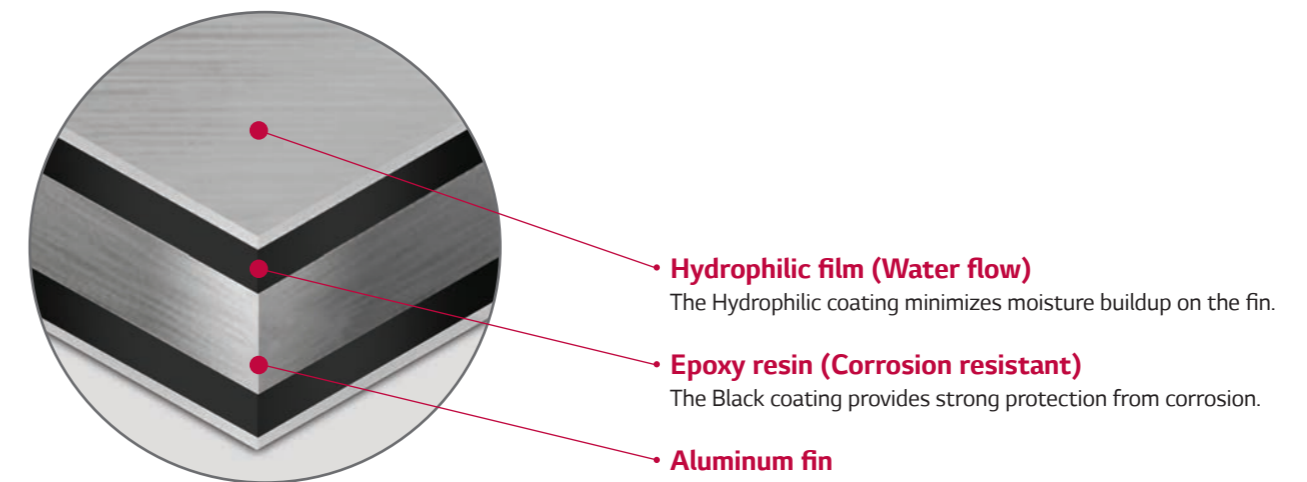

ULTIMATE PERFORMANCE

Larger Capacity ODU with Biomimetics Technology Fan

The moire pattern from external texture of clam shells has been applied on fans to create the range difference which results in reduction of noise level. At the same time, unlike the fans installed in previous products that generate separation of flow due to absence of tubercles, the bumpy back design inspired by the bumps on the humpback whale's flipper is applied as the tubercles on the back side of the fans, increasing wind power by reducing flacking.



Flow difference comparison caused by tubercles

Previous Model vs. MULTI V 5

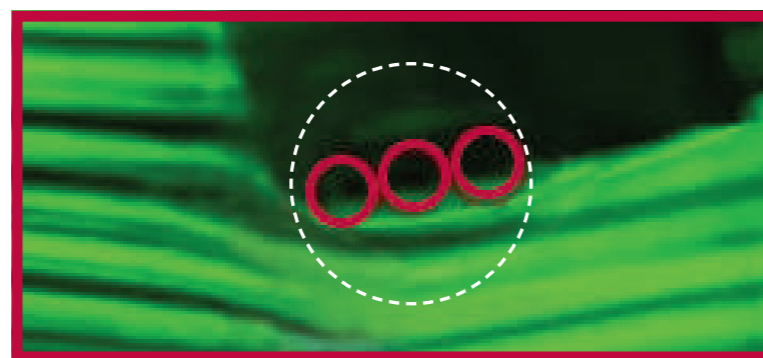
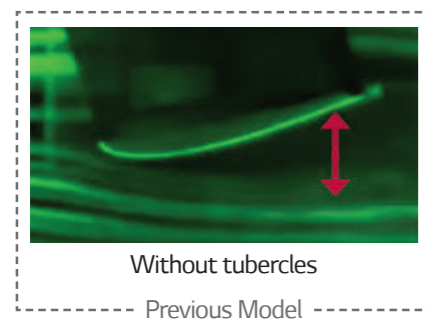

With tubercles

Increased Air Flow Rate with Bigger Shroud

In addition to the biomimetics technology-based fans, **extended shroud of MULTI V 5 allows more high static pressure and helps fans to blow higher air volume for efficient operation.** With wider air guide, discharged air current is stabilized and noise level is reduced.

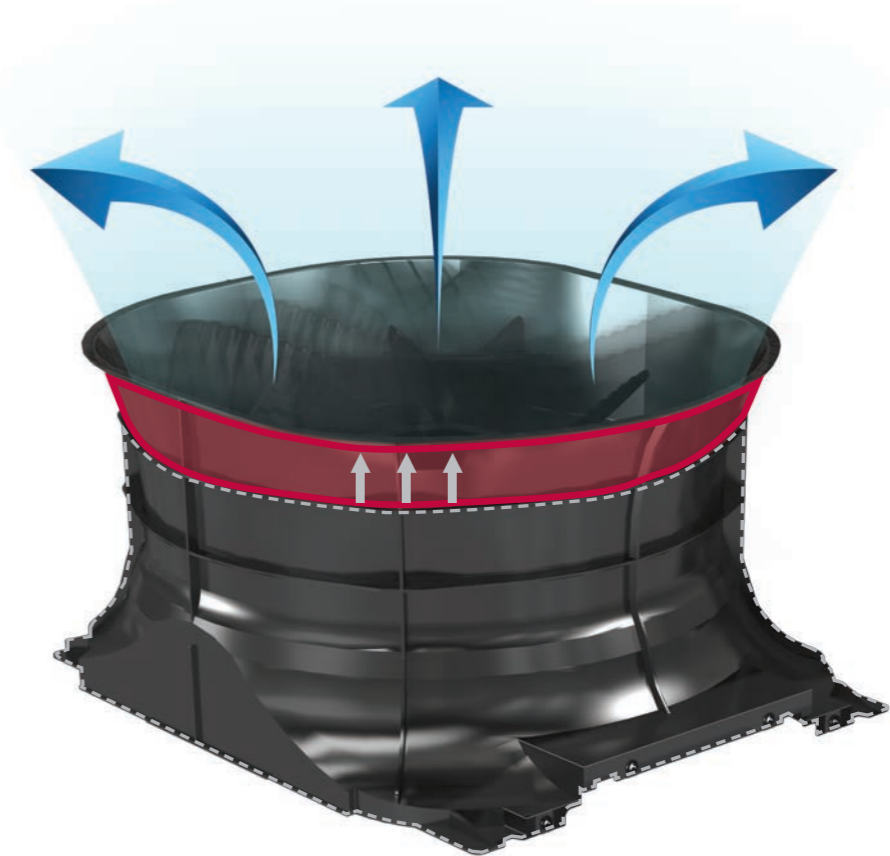

Enhanced Performance with Newly Developed Fan

Based on the **biomimetics technology**, the fans of MULTI V 5 **increased air flow rate by 10% in comparison to previous model and reduced its power consumption up to 20%.** This eventually results in maximized performance with large capacity.

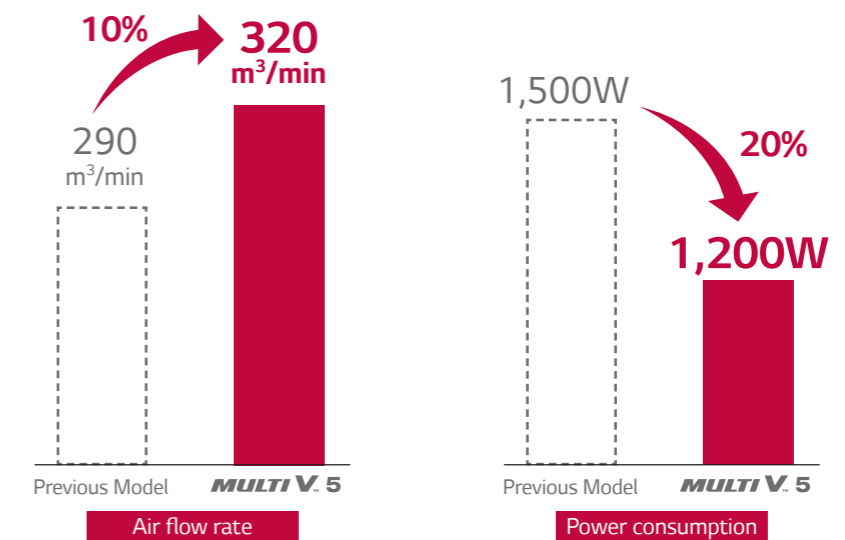

* Comparison based on 20HP model

* Comparison based on air volume of 290m³/min

ULTIMATE PERFORMANCE

Enhanced Bearing with PEEK Material

Motivated by the lubricative material of PEEK(Polyetheretherketone) bearing used for aero engines, the newly invented scroll system with refined shape increases durability and reliability of compressor. It also helps MULTI V 5 to operate longer without oil supply in comparison to the previous models.

Technology mechanism comparison

Previous Model vs. MULTI V 5

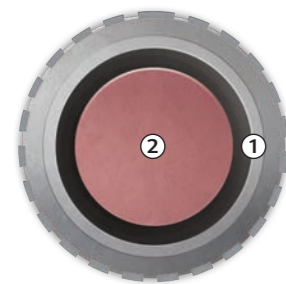
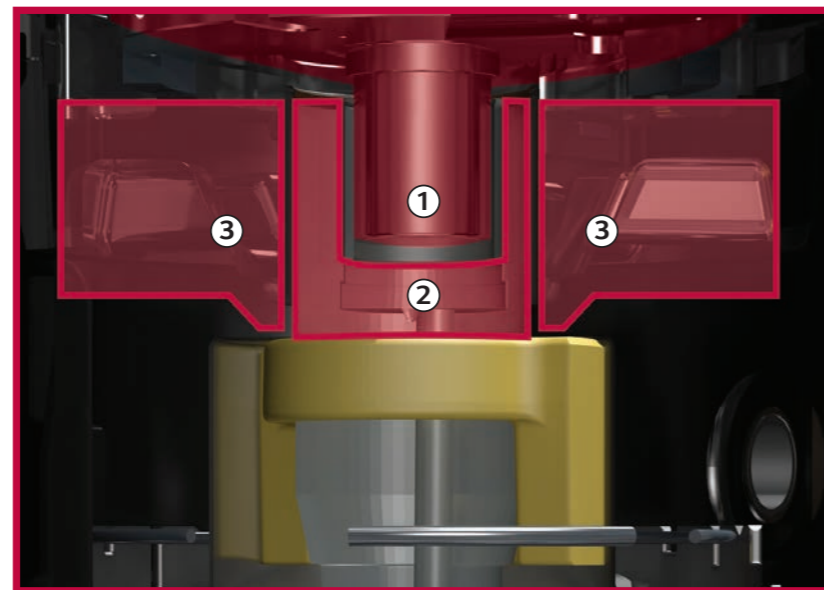
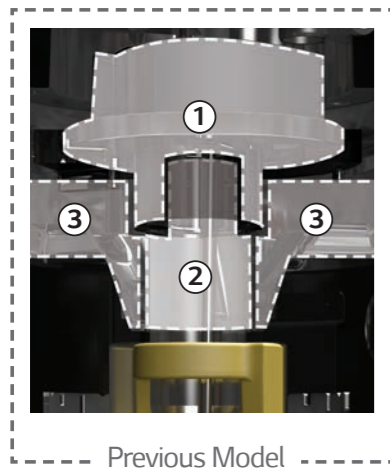

- ① Material : FR160
- ①+② Structure : Inner Bearing
- ③ Supporter

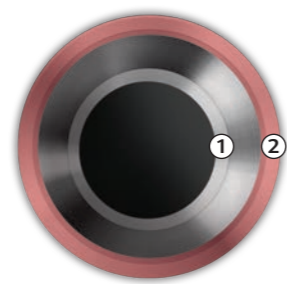

- ① Material : PEEK (Polyetheretherketone)
- ①+② Structure : New Outer Bearing
- ③ Supporter : High speed operation with reduction of bearing load and vibration

Operating time without oil supply
Up to 15%
 Noise Level (Max. Sound Pressure)
Down to 3dB

Oilless operation hours comparison

Previous Model vs. MULTI V 5

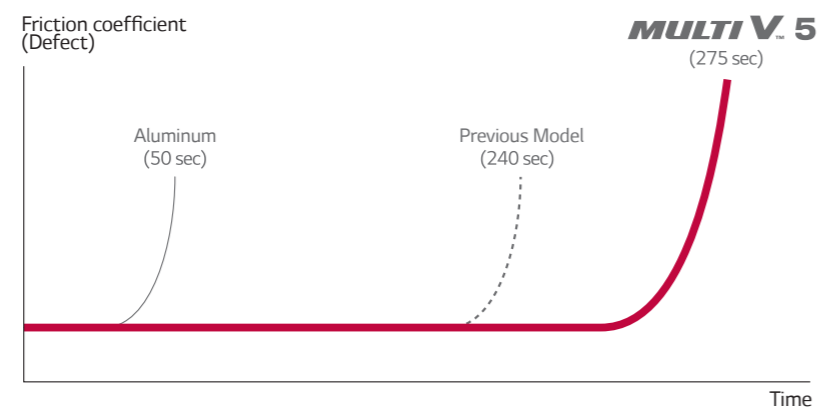

* LG Internal test result
 * Test condition : Bearing oil blocking test (Oil blocking at 60Hz)

Reliable Performance in Extreme Environment

With enhanced inverter compressor and control technology coming from improved supercooling technology installation, vapor injection and Ocean Black Fin, MULTI V 5 extended range of cooling and heating operations. For heating, it can operate at as low as -25°C to perform properly even at very cold environment.

Moreover, MULTI V 5's cycle technology with enhanced durability enables optimal cooling performance at high temperature that increases up to 48°C. It is improved perfectly to fully function at extreme conditions such as performing cooling operation at -15°C, making the product adequate for uses in specialized venues like technical rooms.

Wider operational range for each performance

Previous Model vs. MULTI V 5

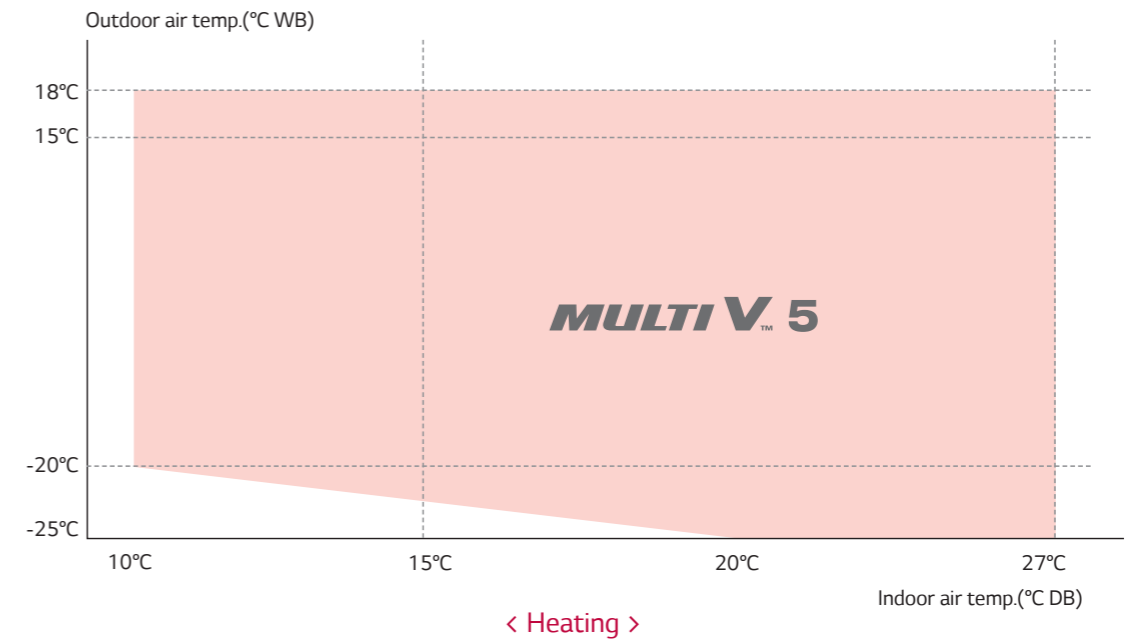

* Under the condition of -25°C for outdoor temperature and 20°C for indoor temperature

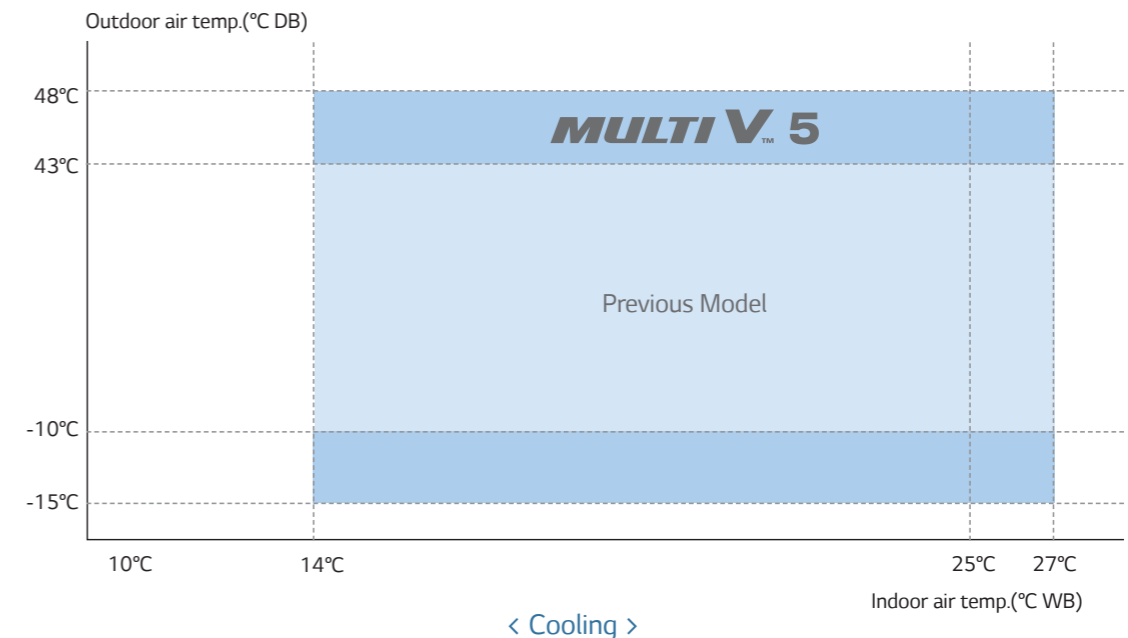

ULTIMATE COMFORT

MULTI V 5 closely senses environment's climate conditions via Dual Sensing Control to control cooling and heating operations. By maintaining specific conditions users set for indoor environment without stopping or changing, MULTI V 5 offers ultimate comfort for the users.

Continuous Heating

With Dual Sensing Control, partial defrost and smart oil management via oil sensor, continuous heating technology has been improved.

- 11% Increase in Heating Operation Time Per Day
- 7% Reduction in Power Input



Delayed Defrost via Humidity Sensor of Dual Sensing Control

By controlling the evaporation temperature considering the humidity, heating operation time is improved.

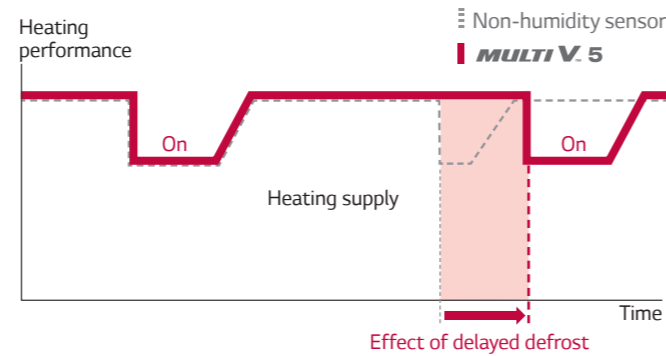

Partial Defrost

Unlike the previous model that stopped heating operation for one-time defrost, MULTI V 5 partially defrosts the heat exchanger by dividing it to lower and upper parts in order to provide consistent heating for the indoor environment and improve heating capacity.

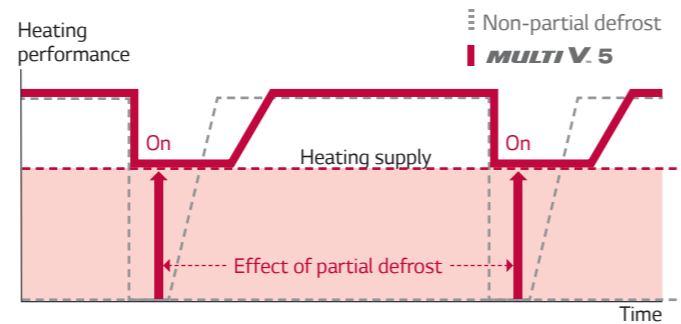
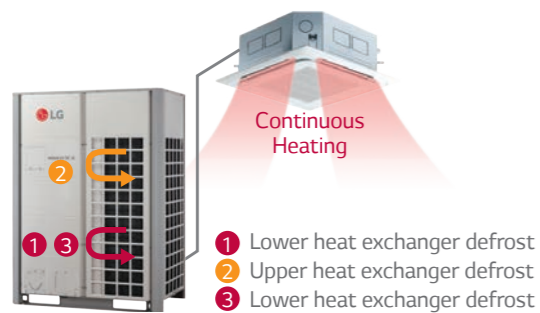

Smart Oil Management

Oil sensor of the Ultimate Inverter (UI) Compressor enables smart oil management to provide enhanced heating operation without periodic oil recovery operation.



Eliminated Unnecessary Oil Return via Oil Sensor

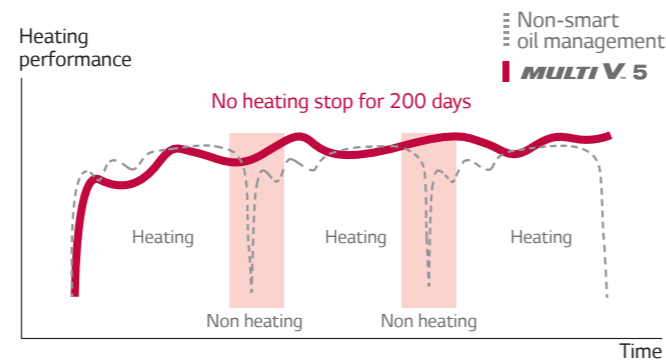

* LG internal test result

ULTIMATE COMFORT

Comfort Cooling

Without stopping in between operations, this function allows MULTI V 5 to maintain operation at mild cooling mode around the set temperature by sensing both temperature and humidity with Dual Sensing Control. By preventing both cold draft and repeated turn on/off's previously required to match the set temperature, users can experience more comfortable indoor environment.



Cooling operation comparison

Previous Model vs. MULTI V 5

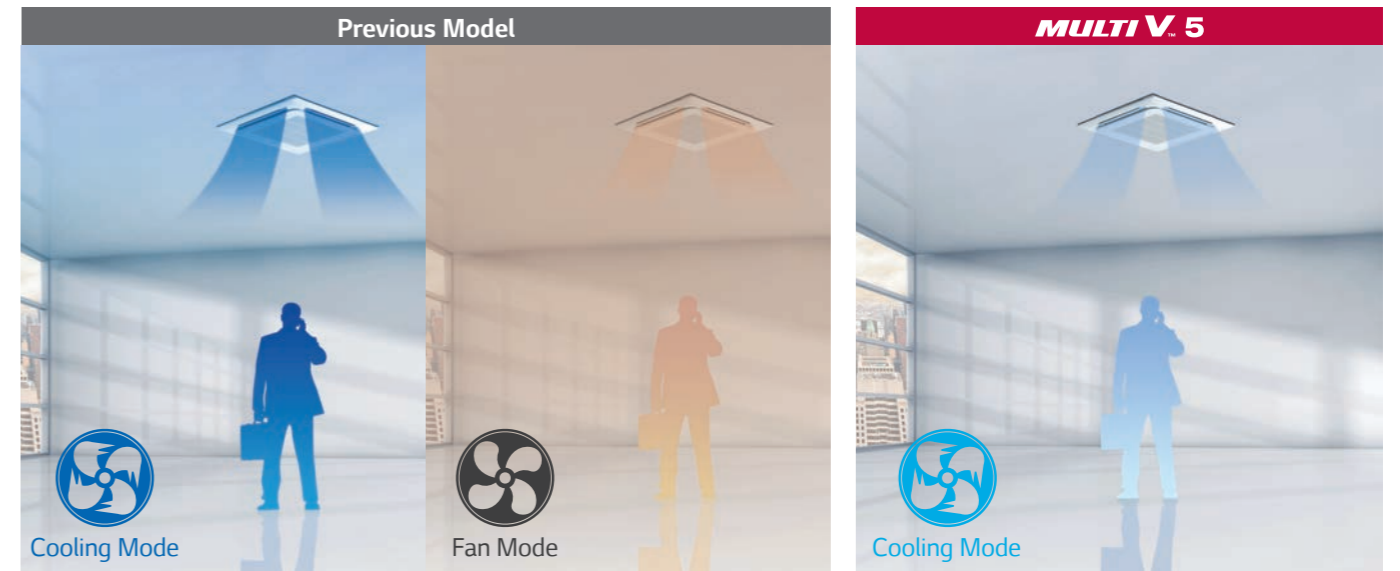

* Indoor unit set up available with Standard III Remote Controller

Preventing cold draft & repeated turn on/off's
Improved indoor comfort

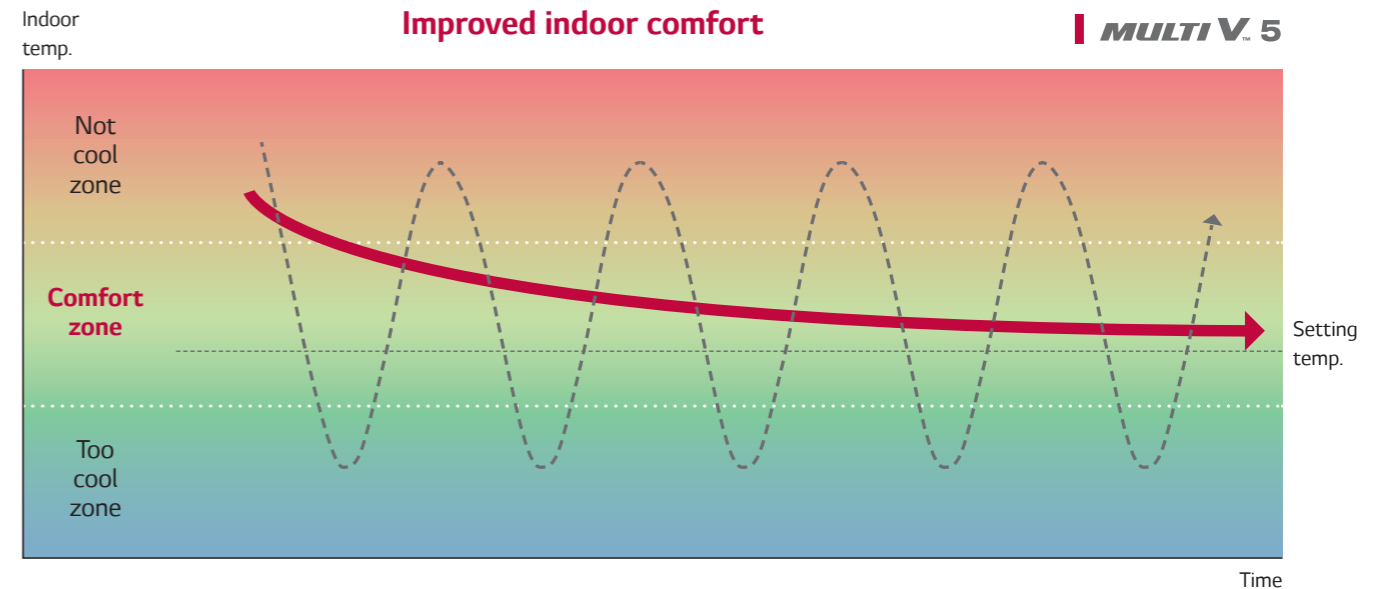

ULTIMATE COMFORT

Low-Noise Operation

Unlike the previous model which enables Low-Noise Operation only during night after judgment time, the Low-Noise Operation of MULTI V 5 can function regardless of the time at the noise sensitive areas.

Operation hours comparison

Previous Model vs. MULTI V 5

Previous Model

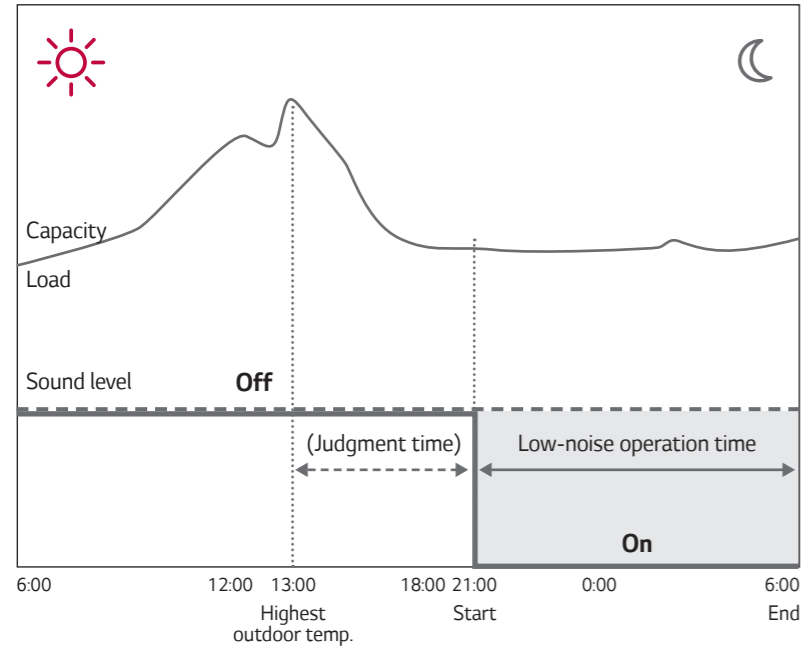

MULTI V 5

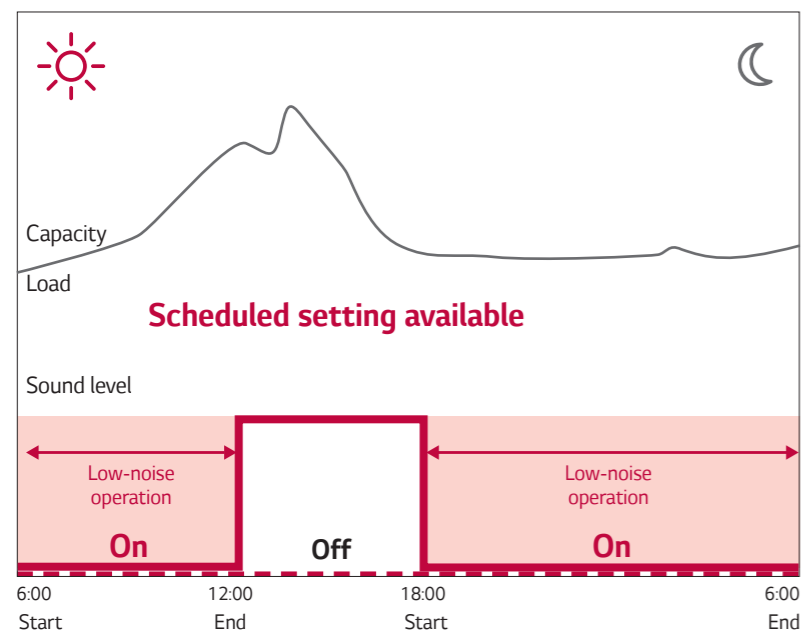

* Indoor unit set up available with Standard III Remote Controller

ULTIMATE FLEXIBILITY

With industry's top level piping technology and large capacity outdoor unit, MULTI V 5 allows users to make better use of the space, offering more flexible installation design.

MULTI V 5 Outdoor Unit Line Up

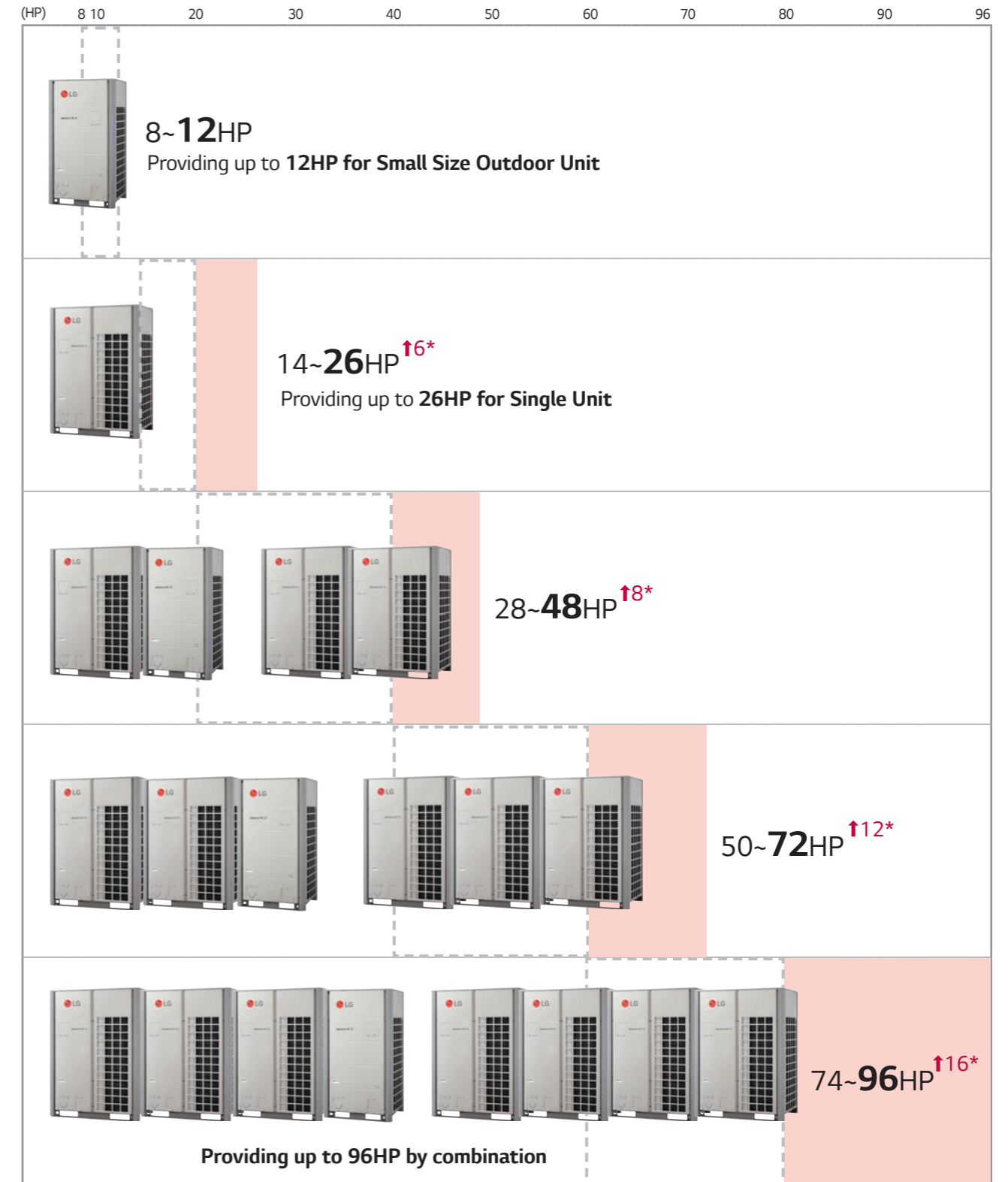

* Capacity increase compared to previous model

ULTIMATE FLEXIBILITY

Flexible Installation Space with Large Capacity Outdoor Units

Large capacity outdoor units of MULTI V 5 minimizes installation space that spares valuable floor space and significantly decreases total installed weights. This allows users the **flexible design potential and better use of the saved space.**

Comparison on installation space

Previous Model vs. MULTI V 5

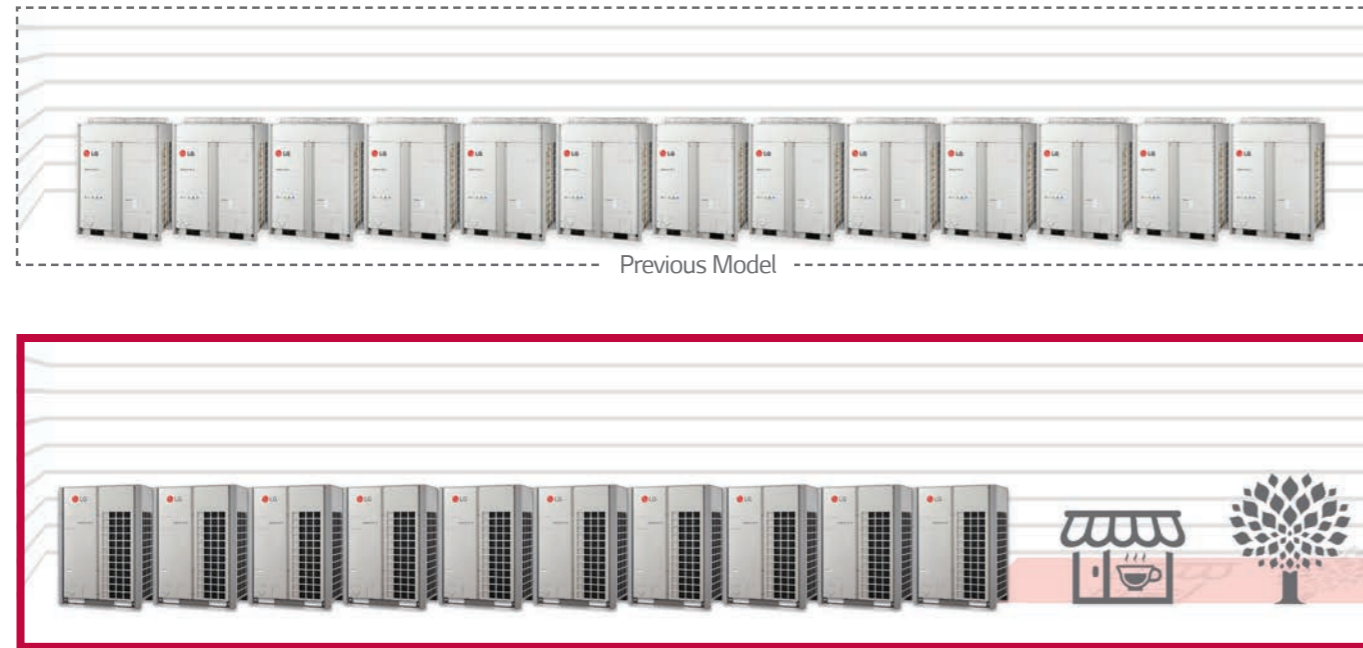

Installation space area and product weight comparison

Previous Model vs. MULTI V 5

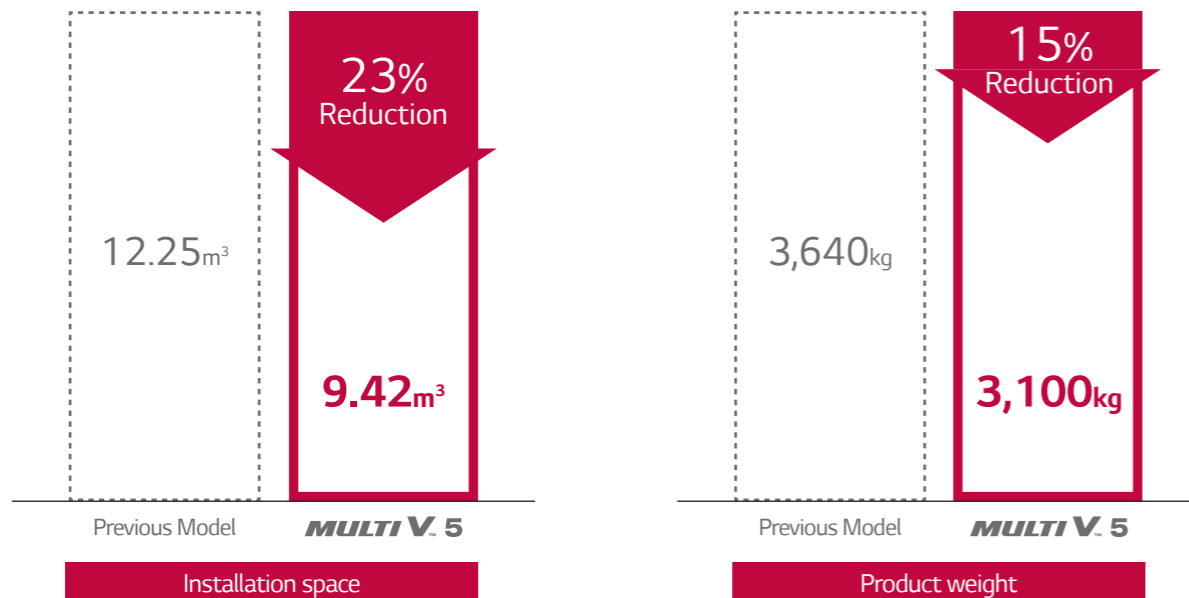

* Comparison basis: 2 Rows of outdoor units 260HP (26HP X 10sets) installation case

Extensive Piping Capabilities for Flexible Installation

Due to improved supercooling circuit and refrigerant controlling technologies, MULTI V 5 allows users to **install world's best class piping lengths, which results in more flexible installation design.**

Piping length

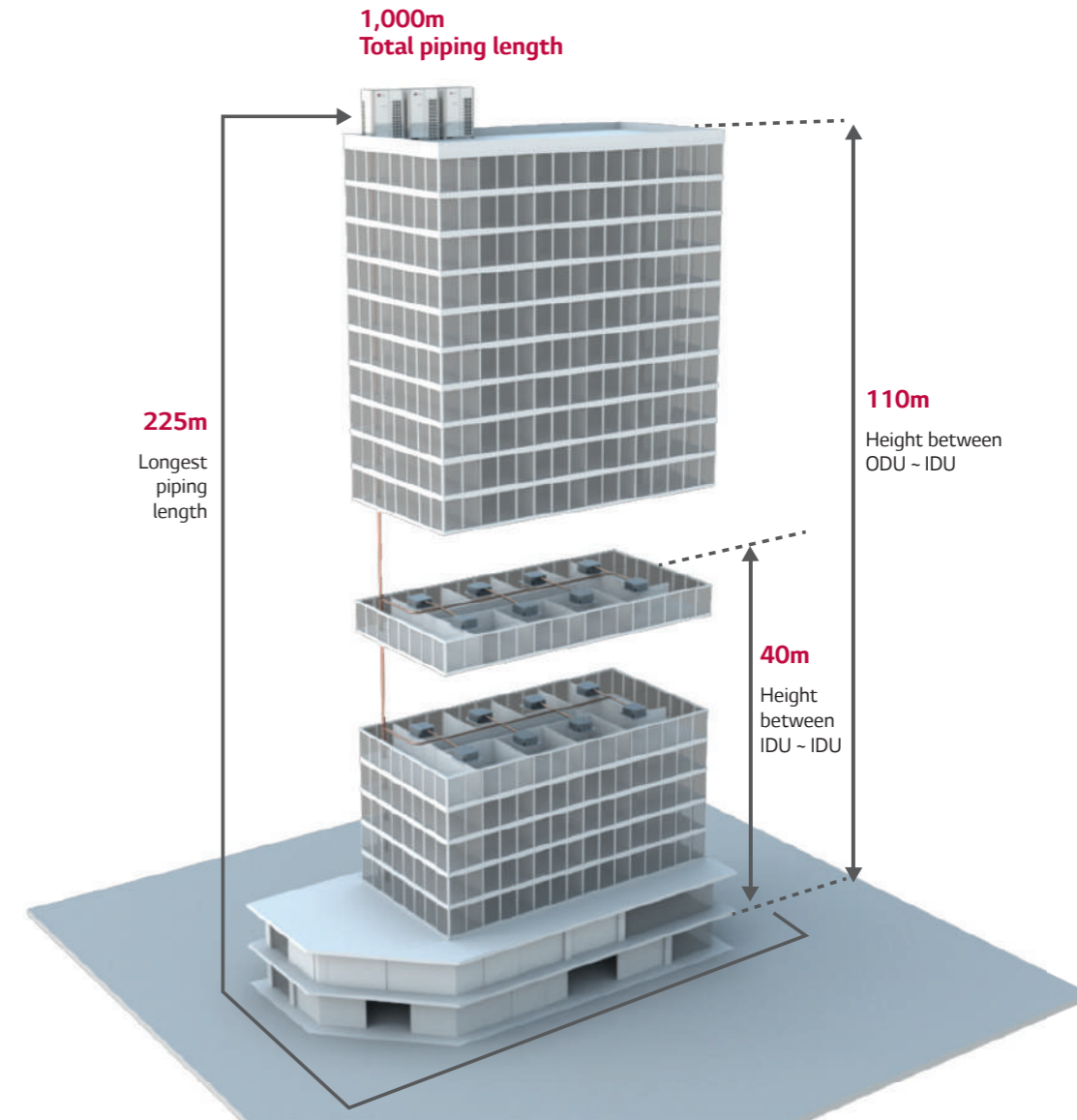

Piping capabilities

Total Piping Length	1,000m
Actual longest piping length (Equivalent)	200m (225m)
Longest piping length after 1 st branch (conditional application)	40m (90m)
Height between ODU ~ IDU	110m
Height between IDU ~ IDU	40m
Height between ODU ~ ODU	5m

ULTIMATE CONTROL

Various maintenance solutions provided by MULTI V 5 offers smart, convenient and reliable functionality.

Energy Management

Energy Management allows MULTI V 5 to analyze previous data in order to forecast energy usage beforehand and **prevent from exceeding the monthly energy consumption plan by systematically controlling the cooling volume**. With energy consulting program that provides automatic operation options for 7 levels of energy management such as compressor capacity management and indoor unit operation level control, users can monitor energy usage anytime and efficiently manage their energy bills.

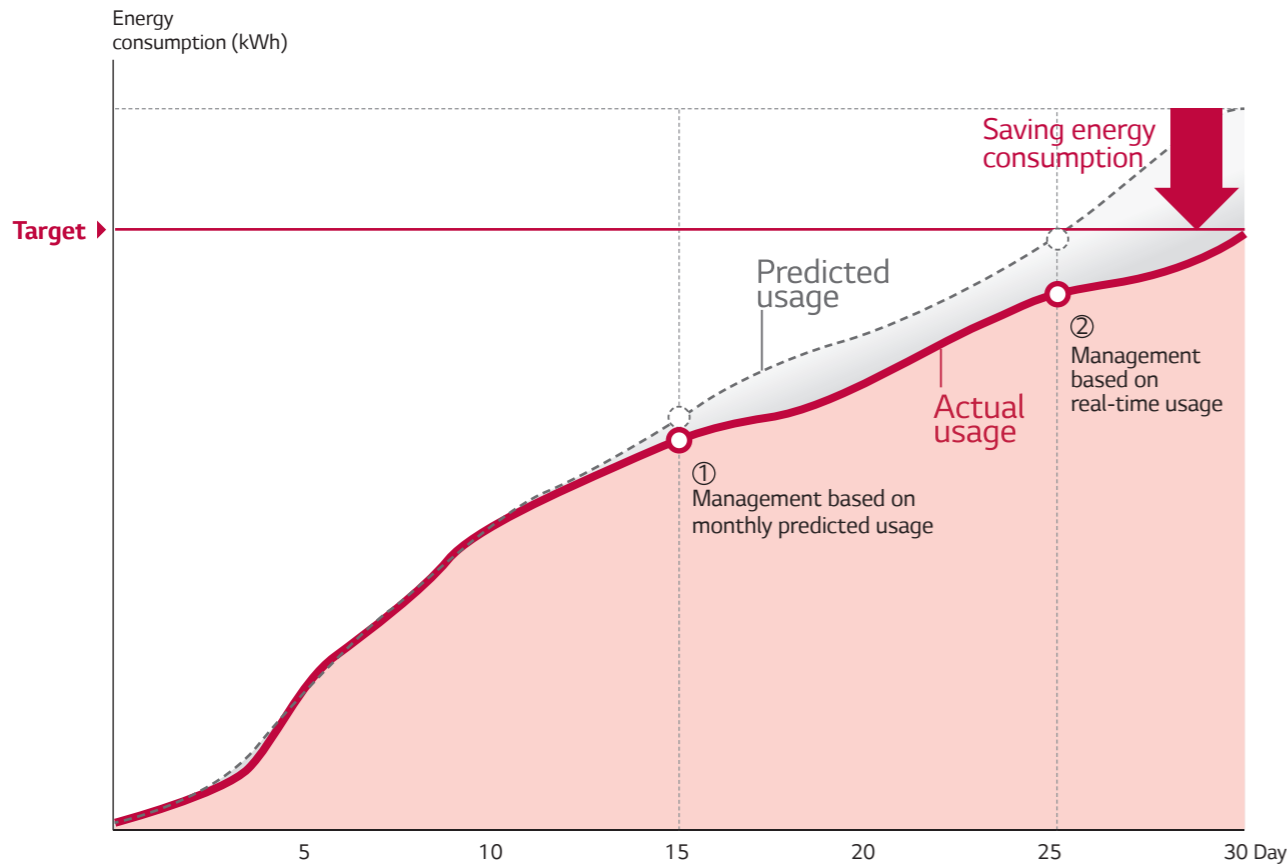

Management setting example

- ① When predicted usage is 120%
- ② When the real-time usage is 90%

* Energy Management allows maximum 7 steps (Input format is percent for predicted and real-time usage)

* Central control kit such as ACP IV or AC Smart IV and PDI are required for energy management function

Control methods

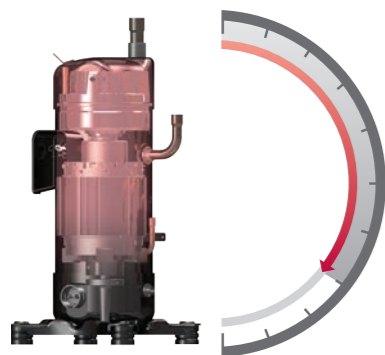

Compressor capacity management



Operation rate control of indoor unit

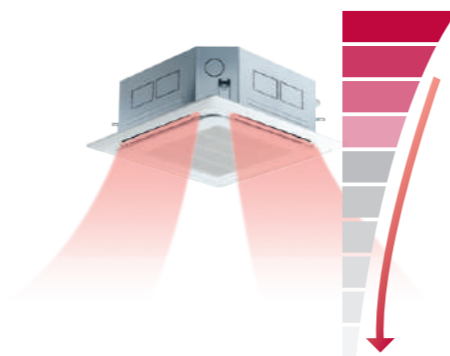

Indoor unit operation management

ULTIMATE CONTROL

AC Manager 5 with User Friendly Interface

As an advanced central controller, AC Manager 5 offers flexible interface for each user by assessing the device screen and automatically customizing the layout to provide the most optimized interface. Moreover, it provides effective system air conditioner management through user friendly interface and various functions.



reddot award
communication design



11:00 am
Monitoring room
[PC]



2:00 pm
Checking each room
[Tablet]



5:00 pm
Monitoring at any time, anywhere
[Mobile]

Various functions of AC Manager 5



Schedule function



Advanced energy monitoring



Operational trend

ULTIMATE CONTROL

Expandability & Programmability

The expandable control system can be interlocked with sensors and facilities of building, as well as air conditioners. It makes building management smart by setting up logic optimized for the site.

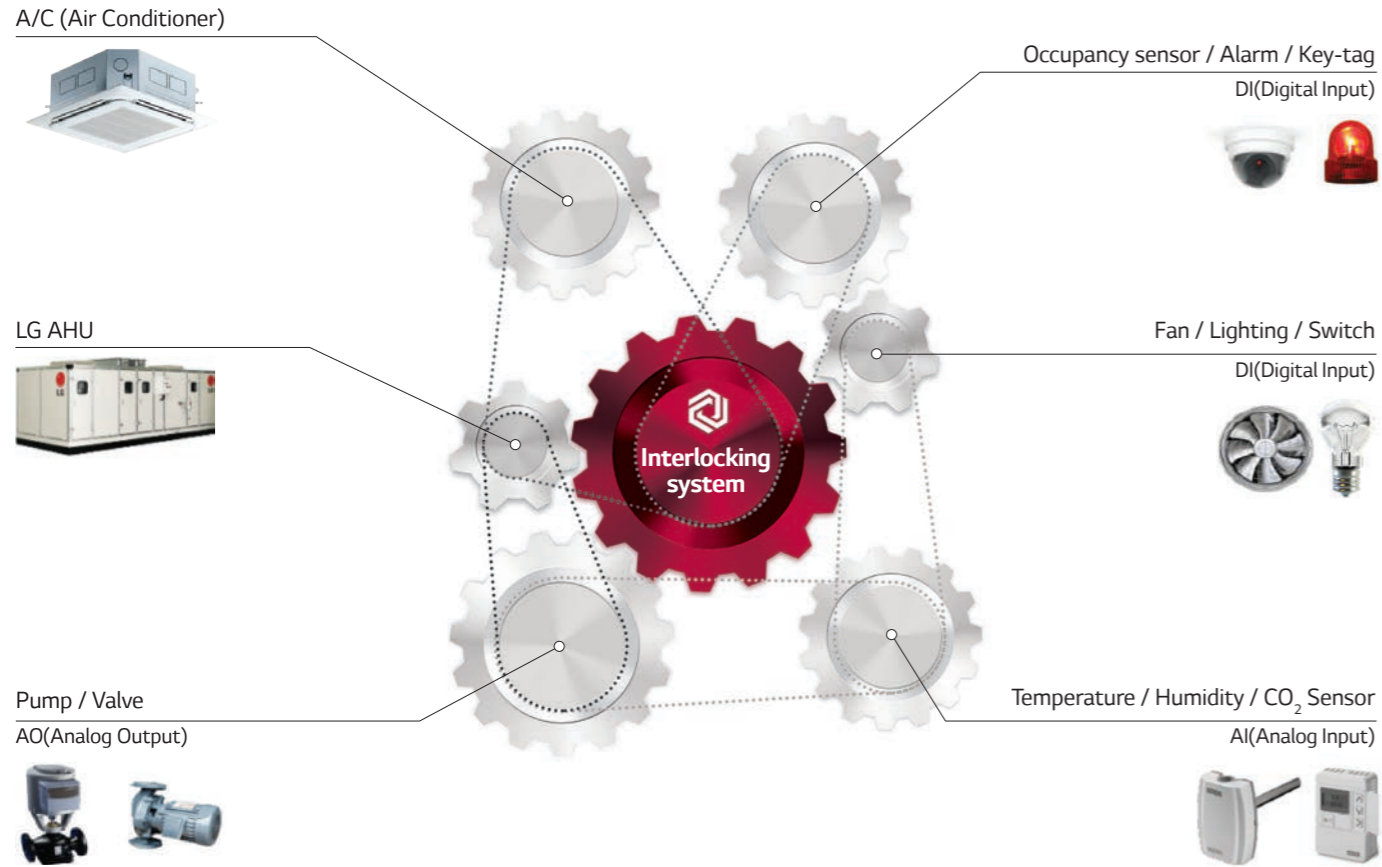

System Flexibility

It can be linked with 3rd party BMS via Gateway and provide flexible control system for each site via Dry Contact.

Interlock with 3rd party BMS



Dry Contact optimized for variable scenario

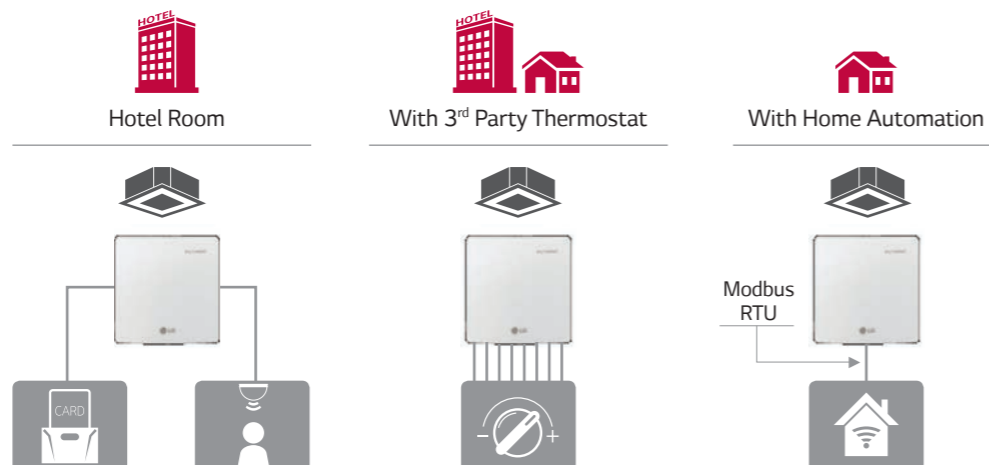

Smart Individual Controller (with Standard III Remote Controller)

New Standard III Remote Controller of MULTI V 5 offers 4.3-inch large LCD screen with neat and premium design. This **luxurious design** well-matches interior design through large colored LCD screen with curved display and simple button layout which makes it easier to control. With **diverse information offered such as temperature, humidity and cleanliness** information, users can check on currently consumed power in real-time and electricity consumption data(weekly/monthly/annually) to **predict and plan power consumption usage**. Moreover, **simple and geometrically neat design of user interface makes data comprehension visually easy**. With circular visual theme, information are labelled in different-sized circles based on their priorities.

Intuitive & Emotional Interface

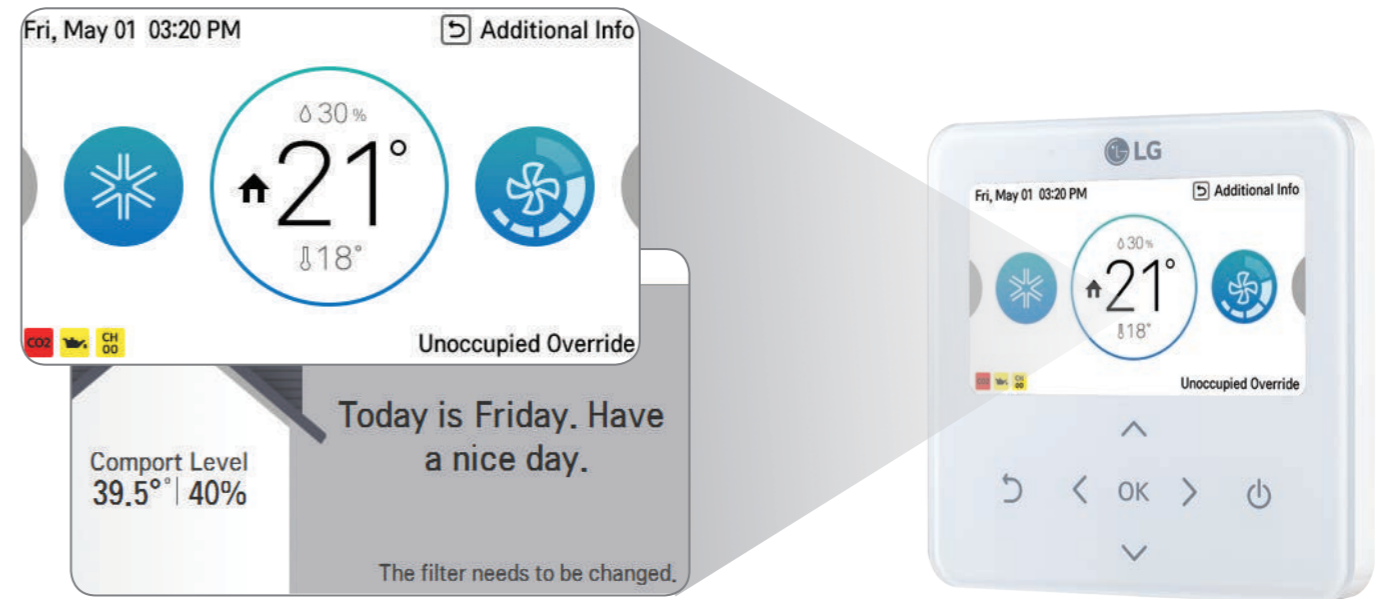

Luxurious Design

Energy Management

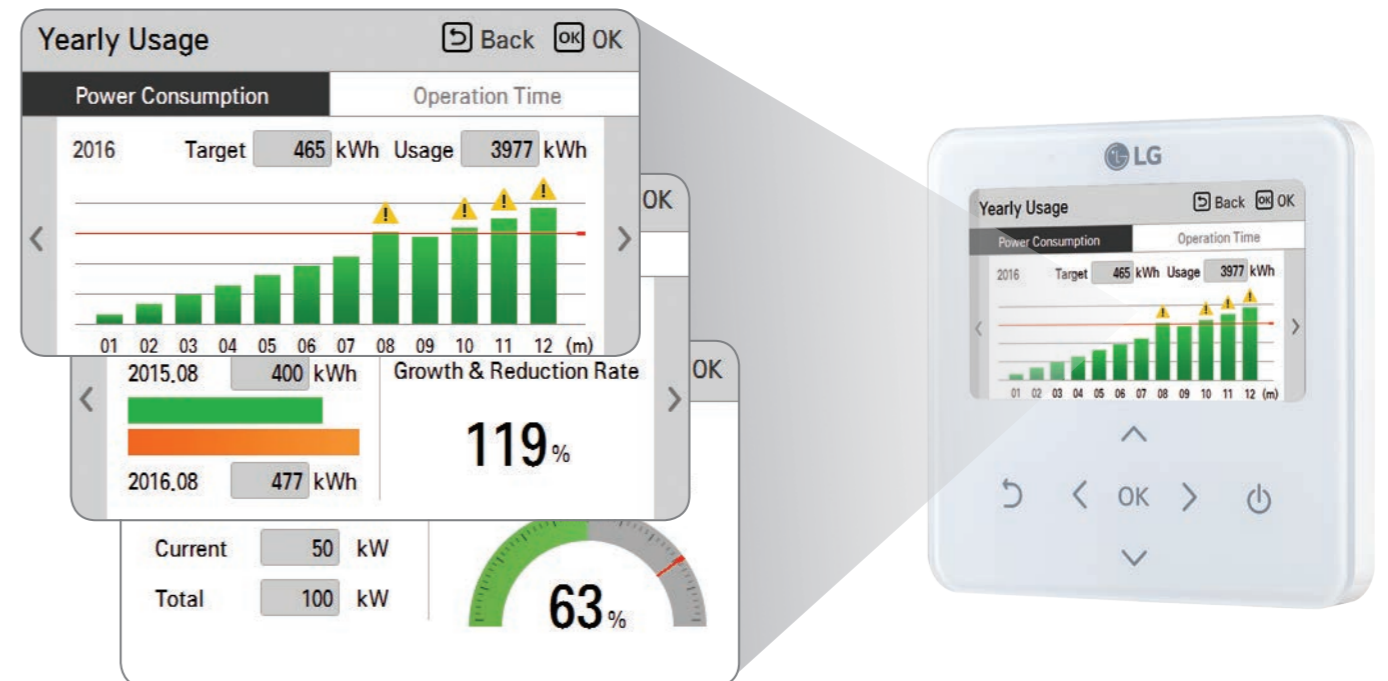

* Central control kit such as ACP IV or AC Smart IV and PDI are required for energy management function

ULTIMATE CONTROL

Simple Test Run via LGMV

In order to bring out performance to the 100% level, proper product test run is necessary. For previous product, professional engineer who is well-aware of more than 40 different functional settings and 200+ error codes had to check main parts in order to make sure that the test run had succeeded. With **Mobile LGMV of MULTI V 5, however, fast and accurate auto test run can be executed** and the professional installer running the test can receive test results via email, which **shortens installation hours and increases overall efficiency in installation processes.**

Test run comparison

Previous Model vs. MULTI V 5

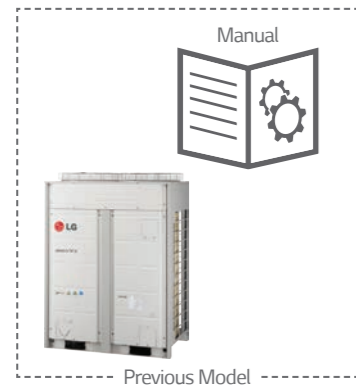

LGMV smartphone application setting pages



Wi-Fi MV Module

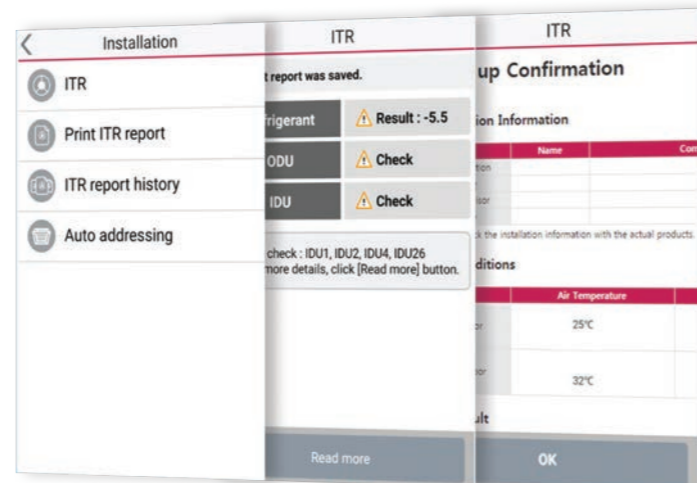

37% Reduction in Installation Hours

* This feature is provided only to qualified professional installers

HEAT RECOVERY

Applicable for Various Building Types with Heat Pump & Heat Recovery Systems

LG MULTI V 5 satisfies users' various needs with just one platform. Heat Pump System works for the sites where either cooling or heating operation is needed, while Heat Recovery System fits perfectly to the sites wherein both the cooling and heating operations are simultaneously needed or locations installed with Hot Water Solution to provide hot water and heating via radiator. By providing suitable solutions that cater to any building types and their requirements, MULTI V 5 offers the best HVAC system.

Simple Piping System Changes

MULTI V 5 allows the building previously installed with Heat Pump System to switch to the Heat Recovery System for changing purpose of the building or remodeling reasons via simple piping construction.

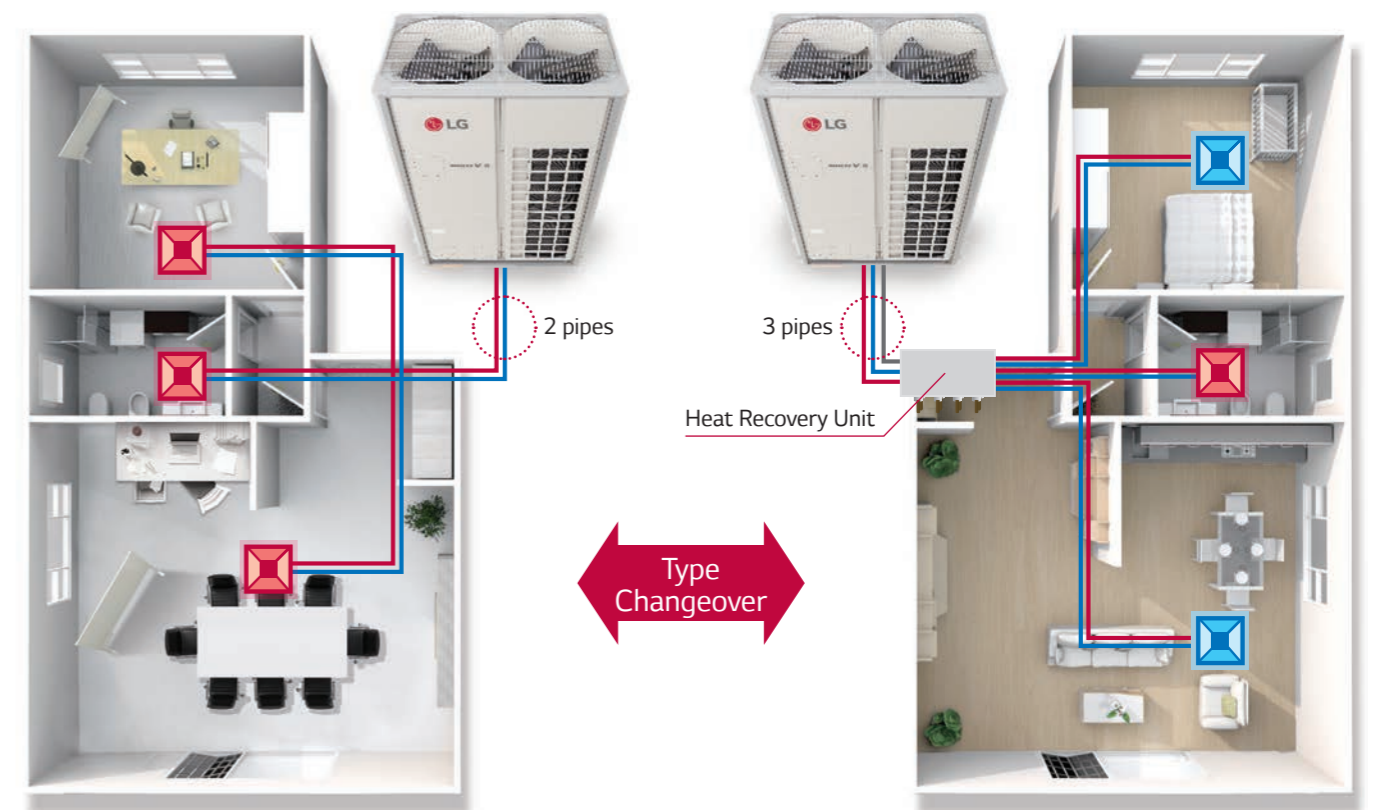

Heat Pump System

Heat Recovery System

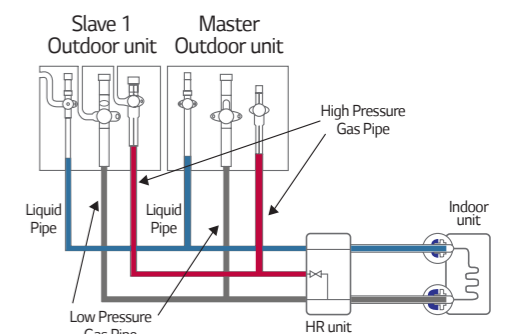
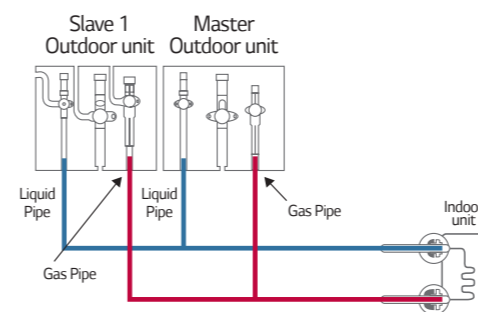

HEAT RECOVERY

Energy Saving with Simultaneous Operation

MULTI V 5 Heat Recovery system with HR Unit can perform both cooling and heating operations simultaneously. For continuous operation, it minimizes in order to switch mode while it increases efficiency with simultaneous operation. Moreover, it allows the COP to reach up to 8.5 under circumstances of 40% cooling and 60% heating operations, which results in the decreased energy consumption up to 30%.

Technology mechanism

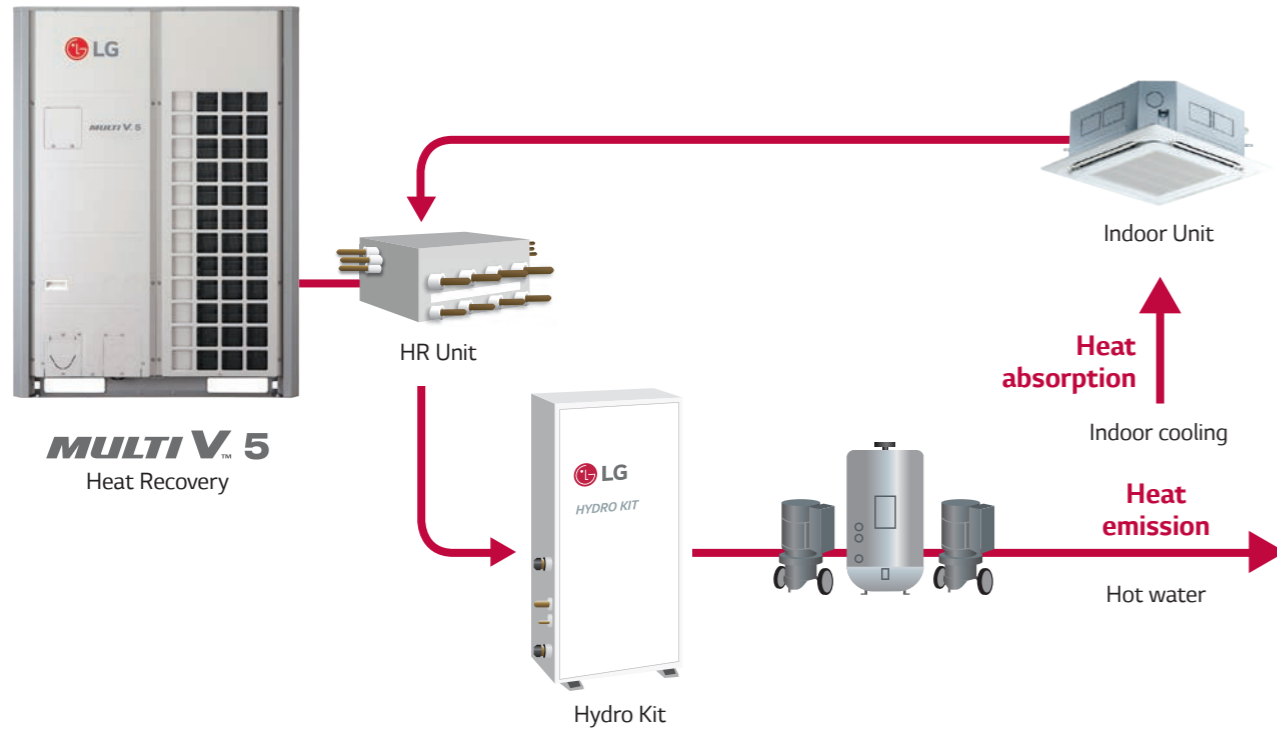

COP with simultaneous operation

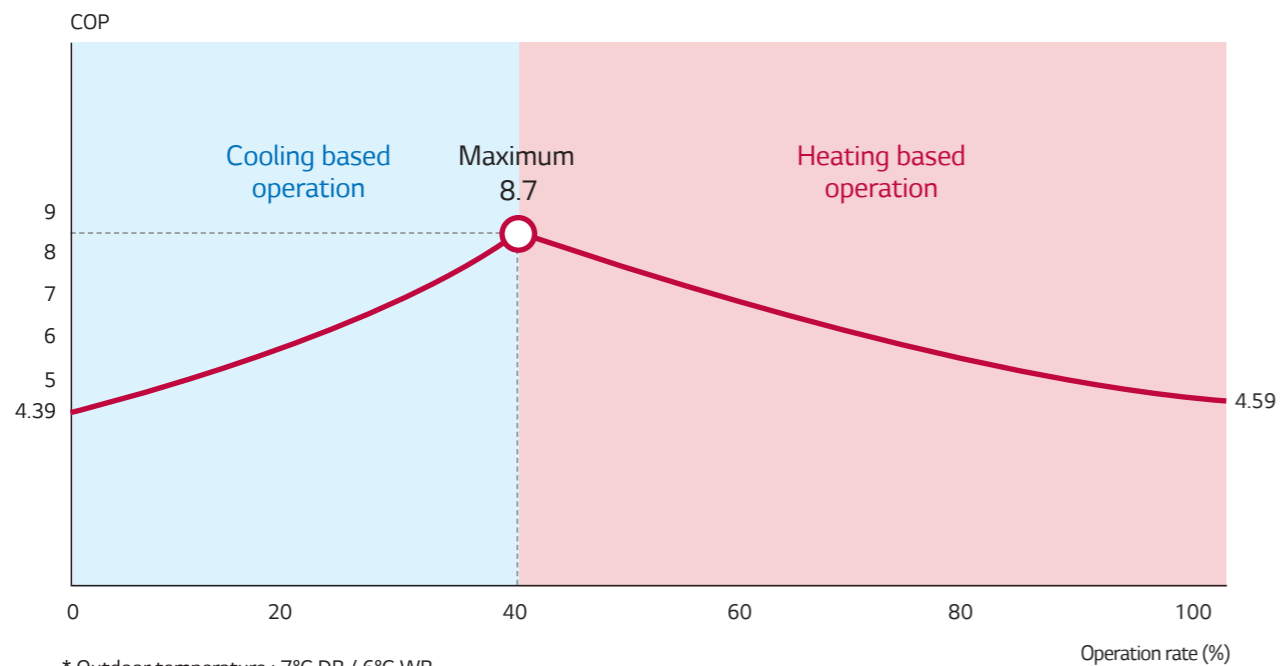

* Outdoor temperature : 7°C DB / 6°C WB
 * Indoor temperature : 20°C DB / 15°C WB
 * ARMU200LTE5

Wide Operation Range

Both the low and high temperature operation ranges are expanded through condenser with various control. For heating mode, the outdoor temperature can go from as low as -25°C to 24°C, and from -15°C to as high as 48°C for cooling mode. As for the synchronous mode, it can run from -10°C to 16°C.

Operation range

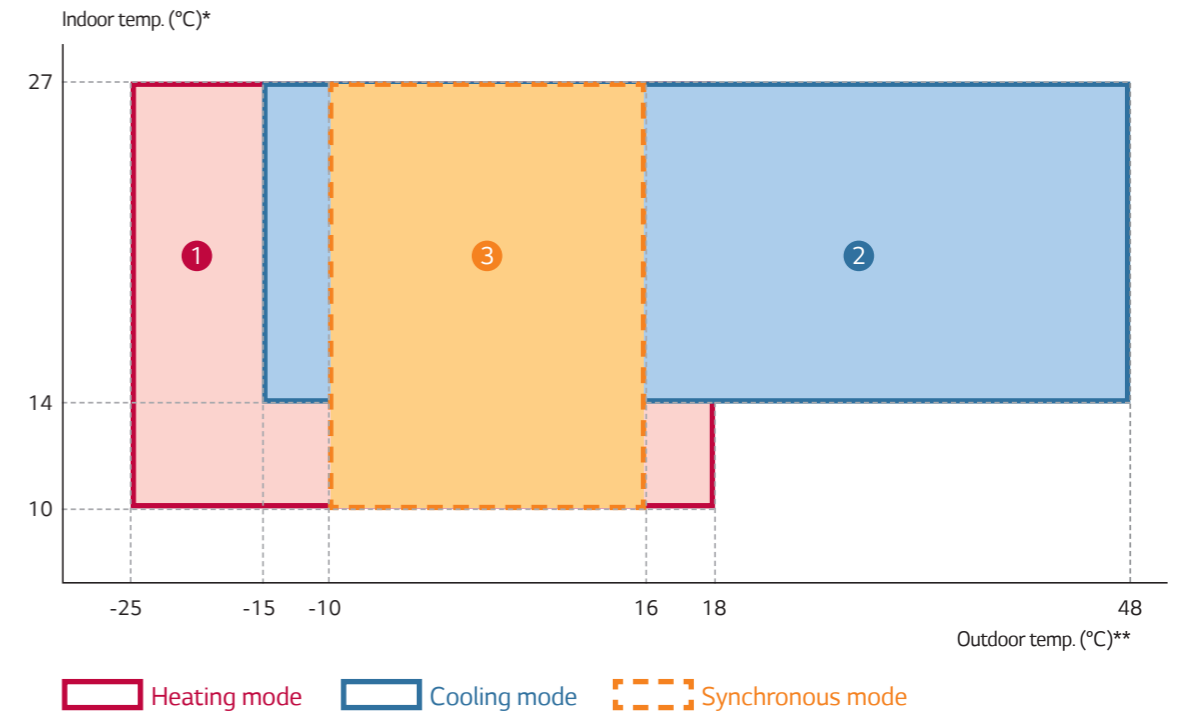

Outdoor Temperature

- ① Heating mode : -25°C WB ~ 18°C WB
- ② Cooling mode : -15°C DB ~ 48°C DB
- ③ Synchronous mode : -10°C WB ~ 16°C WB

* Heating (°C DB), Cooling (°C WB), Synchronous (°C DB)
 ** Heating (°C WB), Cooling (°C DB), Synchronous (°C WB)

Flexible Connection of Heat Recovery Unit

LG MULTI V 5 Heat Recovery Unit allows flexible connection both in series and in a row. With the zone control function, up to 8 indoor units can be connected to a branch while the maximum of 32 indoor units can be connected to a HR unit, saving the installation cost by flexible connection.

Zoning control

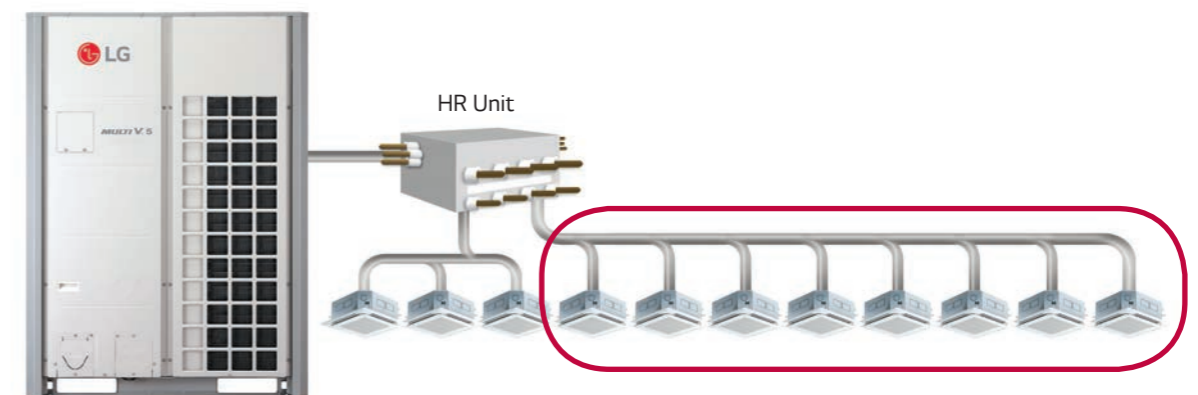

Table with columns for HP, Model Name, Capacity, Input, COP, Power Factor, Casing Color, Heat Exchanger, Compressor, Fan, Pipe Connections, Dimensions, Net Weight, Sound Pressure Level, Protection Devices, Communication Cable, Refrigerant, and Power Supply. It provides detailed specifications for various models across multiple categories.

* This product contains Fluorinated Greenhouse Gases. (R410A)

Table with columns for HP, Model Name, Capacity, Input, COP, Power Factor, Casing Color, Heat Exchanger, Compressor, Fan, Pipe Connections, Dimensions, Net Weight, Sound Pressure Level, Protection Devices, Communication Cable, Refrigerant, and Power Supply. It provides detailed specifications for various models across multiple categories.

* This product contains Fluorinated Greenhouse Gases. (R410A)

HP		86	88	90	92	94	96	
Model Name	Combination Unit	ARUM860LTE5	ARUM880LTE5	ARUM900LTE5	ARUM920LTE5	ARUM940LTE5	ARUM960LTE5	
	Independent Unit	ARUM240LTE5 ARUM240LTE5 ARUM240LTE5 ARUM140LTE5	ARUM240LTE5 ARUM240LTE5 ARUM240LTE5 ARUM160LTE5	ARUM240LTE5 ARUM240LTE5 ARUM240LTE5 ARUM180LTE5	ARUM240LTE5 ARUM240LTE5 ARUM240LTE5 ARUM200LTE5	ARUM240LTE5 ARUM240LTE5 ARUM240LTE5 ARUM220LTE5	ARUM240LTE5 ARUM240LTE5 ARUM240LTE5 ARUM240LTE5	
Capacity	Cooling (Rated)	kW	240.8	246.4	252.0	257.6	263.2	268.8
		Btu/h	821,600	840,700	859,800	878,900	898,000	917,100
	Heating (Rated)	kW	240.8	246.4	252.0	257.6	263.2	268.8
		Btu/h	821,600	840,700	859,800	878,900	898,000	917,100
	Heating (Max)	kW	266.9	273.2	279.5	285.8	292.1	297.0
		Btu/h	910,600	932,000	953,500	975,000	996,500	1,013,400
Input	Cooling (Rated)	kW	60.9	63.1	63.1	65.0	67.9	69.6
	Heating (Rated)	kW	55.8	58.0	57.8	59.9	61.8	63.6
	Heating (Max)	kW	66.1	68.8	68.3	71.1	73.2	75.2
EER			3.96	3.91	3.99	3.96	3.88	3.86
ESEER			6.68	6.57	6.72	6.66	6.60	6.57
ESEER (SLC)			8.07	8.00	8.04	7.95	8.00	8.05
COP	COP (Rated)		4.32	4.25	4.36	4.30	4.26	4.23
	COP (Max)		4.04	3.97	4.09	4.02	3.99	3.95
Power Factor	Rated	-	0.93	0.93	0.93	0.93	0.93	0.93
Casing Color			Warm Gray / Dawn Gray	Warm Gray / Dawn Gray	Warm Gray / Dawn Gray	Warm Gray / Dawn Gray	Warm Gray / Dawn Gray	Warm Gray / Dawn Gray
Heat Exchanger			Ocean Black Fin	Ocean Black Fin	Ocean Black Fin	Ocean Black Fin	Ocean Black Fin	Ocean Black Fin
Compressor	Type		Hermetically Sealed Scroll	Hermetically Sealed Scroll	Hermetically Sealed Scroll	Hermetically Sealed Scroll	Hermetically Sealed Scroll	Hermetically Sealed Scroll
	Piston Displacement	cm ³ /rev	62.1 × 7	62.1 × 7	(62.1 × 7) + (43.8 × 1)	(62.1 × 7) + (43.8 × 1)	(62.1 × 7) + (43.8 × 1)	62.1 × 8
	Number of Revolution	rev/min	3,600 × 7	3,600 × 7	3,600 × 8	3,600 × 8	3,600 × 8	3,600 × 8
	Motor Output × Number	W × No.	5,300 × 7	5,300 × 7	(5,300 × 7) + (4,200 × 1)	(5,300 × 7) + (4,200 × 1)	(5,300 × 7) + (4,200 × 1)	5,300 × 8
	Starting Method		Direct On Line	Direct On Line	Direct On Line	Direct On Line	Direct On Line	Direct On Line
Oil Type			FVC68D(PVE)	FVC68D(PVE)	FVC68D(PVE)	FVC68D(PVE)	FVC68D(PVE)	FVC68D(PVE)
Fan	Type		Propeller fan	Propeller fan	Propeller fan	Propeller fan	Propeller fan	Propeller fan
	Motor Output × Number	W	900 × 8	900 × 8	900 × 8	900 × 8	900 × 8	900 × 8
	Air Flow Rate (High)	m ³ /min	320 × 4	320 × 4	320 × 4	320 × 4	320 × 4	320 × 4
		ft ³ /min	11,301 × 4	11,301 × 4	11,301 × 4	11,301 × 4	11,301 × 4	11,301 × 4
	Drive		DC INVERTER	DC INVERTER	DC INVERTER	DC INVERTER	DC INVERTER	DC INVERTER
Discharge		Side / Top	TOP	TOP	TOP	TOP	TOP	
Pipe Connections For Heat Recovery	Liquid Pipe	mm(inch)	22.2(7/8)	22.2(7/8)	22.2(7/8)	22.2(7/8)	22.2(7/8)	22.2(7/8)
	Low Pressure Gas Pipe	mm(inch)	53.98(2-1/8)	53.98(2-1/8)	53.98(2-1/8)	53.98(2-1/8)	53.98(2-1/8)	53.98(2-1/8)
	High Pressure Gas Pipe	mm(inch)	44.5(1-3/4)	44.5(1-3/4)	44.5(1-3/4)	44.5(1-3/4)	44.5(1-3/4)	44.5(1-3/4)
Pipe Connections For Heat Pump	Liquid Pipe	mm(inch)	22.2(7/8)	22.2(7/8)	22.2(7/8)	22.2(7/8)	22.2(7/8)	22.2(7/8)
	Gas Pipe	mm(inch)	53.98(2-1/8)	53.98(2-1/8)	53.98(2-1/8)	53.98(2-1/8)	53.98(2-1/8)	53.98(2-1/8)
Dimensions(W × H × D)		mm	(1,240 × 1,690 × 760) × 4	(1,240 × 1,690 × 760) × 4	(1,240 × 1,690 × 760) × 4	(1,240 × 1,690 × 760) × 4	(1,240 × 1,690 × 760) × 4	(1,240 × 1,690 × 760) × 4
		inch	(48-13/16 × 66-17/32 × 29-29/32) × 4	(48-13/16 × 66-17/32 × 29-29/32) × 4	(48-13/16 × 66-17/32 × 29-29/32) × 4	(48-13/16 × 66-17/32 × 29-29/32) × 4	(48-13/16 × 66-17/32 × 29-29/32) × 4	(48-13/16 × 66-17/32 × 29-29/32) × 4
Net Weight		kg	(310 × 3) + (237 × 1)	(310 × 3) + (237 × 1)	(310 × 3) + (300 × 1)	(310 × 3) + (300 × 1)	(310 × 3) + (300 × 1)	310 × 4
		lbs	(683 × 3) + (522 × 1)	(683 × 3) + (522 × 1)	(683 × 3) + (661 × 1)	(683 × 3) + (661 × 1)	(683 × 3) + (661 × 1)	683 × 4
Sound Pressure Level	Cooling	dB(A)	70.2	70.3	70.3	70.4	70.9	71.0
	Heating	dB(A)	72.1	72.2	72.2	72.5	72.7	73.0
Sound Power Level	Cooling	dB(A)	93.1	93.2	93.4	93.6	93.6	94.0
	Heating	dB(A)	95.1	95.2	95.3	95.4	95.6	96.0
Protection Devices	High pressure protection	-	High pressure sensor / High pressure switch	High pressure sensor / High pressure switch	High pressure sensor / High pressure switch	High pressure sensor / High pressure switch	High pressure sensor / High pressure switch	High pressure sensor / High pressure switch
	Compressor/Fan	-	Over-heat protection / Fan driver overload protector	Over-heat protection / Fan driver overload protector	Over-heat protection / Fan driver overload protector	Over-heat protection / Fan driver overload protector	Over-heat protection / Fan driver overload protector	Over-heat protection / Fan driver overload protector
	Inverter	-	Over-heat protection / Over-current protection	Over-heat protection / Over-current protection	Over-heat protection / Over-current protection	Over-heat protection / Over-current protection	Over-heat protection / Over-current protection	Over-heat protection / Over-current protection
Communication Cable		No. × mm ² (VCTF-SB)	2C × 1.0 - 1.5	2C × 1.0 - 1.5	2C × 1.0 - 1.5	2C × 1.0 - 1.5	2C × 1.0 - 1.5	2C × 1.0 - 1.5
Refrigerant	Refrigerant name		R410A	R410A	R410A	R410A	R410A	R410A
	Precharged Amount in factory	kg	64.5	64.5	67.0	67.0	67.0	68.0
		lbs	142.2	142.2	147.7	147.7	147.7	149.9
	GWP			2,087.5	2,087.5	2,087.5	2,087.5	2,087.5
	TCO _{eq}			134.6	134.6	139.9	139.9	142.0
Control			Electronic Expansion Valve	Electronic Expansion Valve	Electronic Expansion Valve	Electronic Expansion Valve	Electronic Expansion Valve	
Power Supply	Ø, V, Hz		380-415, 3, 50	380-415, 3, 50	380-415, 3, 50	380-415, 3, 50	380-415, 3, 50	380-415, 3, 50
			380, 3, 60	380, 3, 60	380, 3, 60	380, 3, 60	380, 3, 60	380, 3, 60
Number of maximum connectable indoor units			64	64	64	64	64	64

* This product contains Fluorinated Greenhouse Gases. (R410A)

Notes

1. Eurovent Test Condition : Maximum 8 Indoor units are connected (Indoor unit type is Ceiling Concealed Duct)

- Refer to EUROVENT certification regulation for more detail test conditions.
- Performances of Combination units are sum of Independent unit (Outdoor Units).

2. Capacities are based on the following conditions :

- Cooling Temperature : Indoor 27°C(80.6°F) DB / 19°C(66.2°F) WB
Outdoor 35°C(95°F) DB / 24°C(75.2°F) WB
- Heating Temperature : Indoor 20°C(68°F) DB / 15°C(59°F) WB
Outdoor 7°C(44.6°F) DB / 6°C(42.8°F) WB
- Piping Length : Interconnected Pipe Length = 7.5m
- Difference Limit of Elevation (Outdoor ~ Indoor Unit) is Zero.

3. Wiring cable size must comply with the applicable local and national code.

4. Sound Level Values can be increased owing to ambient conditions during operation.

5. The numbers in parentheses means maximum connectable indoor units in accordance with outdoor units combination. The recommended ratio is 130%.

6. ESEER calculation corresponds with below conditions and power input of indoor units is not included.

- Indoor temperature : 27°C(80.6°F) DB / 19°C(66.2°F) WB
- Outdoor Temperature conditions.

Part Load Ratio	Outdoor Air Temp.(°C(°F)DB)	Weighting Coefficients
100%	35 (95)	0.03
75%	30 (86)	0.33
50%	25 (77)	0.41
25%	20 (68)	0.23

- Formula : 0.03 × EER100% + 0.33 × EER75% + 0.41 × EER50% + 0.23 × EER25%

7. Due to our policy of innovation some specifications may be changed without notification.

8. Power factor could vary less than ±1% according to the operating conditions.

9. This product contains Fluorinated greenhouse gases.



LG Electronics

<http://www.lg.com>
<http://partner.lge.com>

Copyright © 2017 LG Electronics. All rights reserved

Distributed by